

## IMS Applications in MSF Architecture

### GMI2006 Interoperability Testing of Value-Added Services

John Wullert

Representing the National Communications System

[wullert@research.telcordia.com](mailto:wullert@research.telcordia.com)

732-699-2687



# Outline

- GMI 2006 Value Added Services
- Service Scenarios
  - Single Domain
  - Roaming
- Sample service flows
- Summary

# Value Added Services at GMI2006

## Goals

- Exploit the MSF communications infrastructure for purposes beyond voice calls
  - Validate interoperability between signaling plane and application plane elements
- Demonstrate multiple methods of implementing NGN services
  - Parlay application servers
  - Parlay X application servers
  - SIP application servers
- Manage application interactions using Service Broker/SCIM

# Global MSF Interoperability Event 2006

## Physical Scenarios

1. Basic calls in single domain
  - Supporting both SIP and PSTN subscriber terminals.
- 2. Single domain with value added services.**
  - **Adding SIP and Parlay/OSA applications.**
3. IMS Interconnect
  - Interconnection between subscribers in the MSF R3 domain and subscribers in other domains
4. Roaming
  - Demonstrate roaming of subscriber terminals between different instances of MSF R3 networks
- 5. Roaming with value added services**
  - **Demonstrate delivery of value added services to roaming subscribers**

# Scenario 2

## Network Diagram

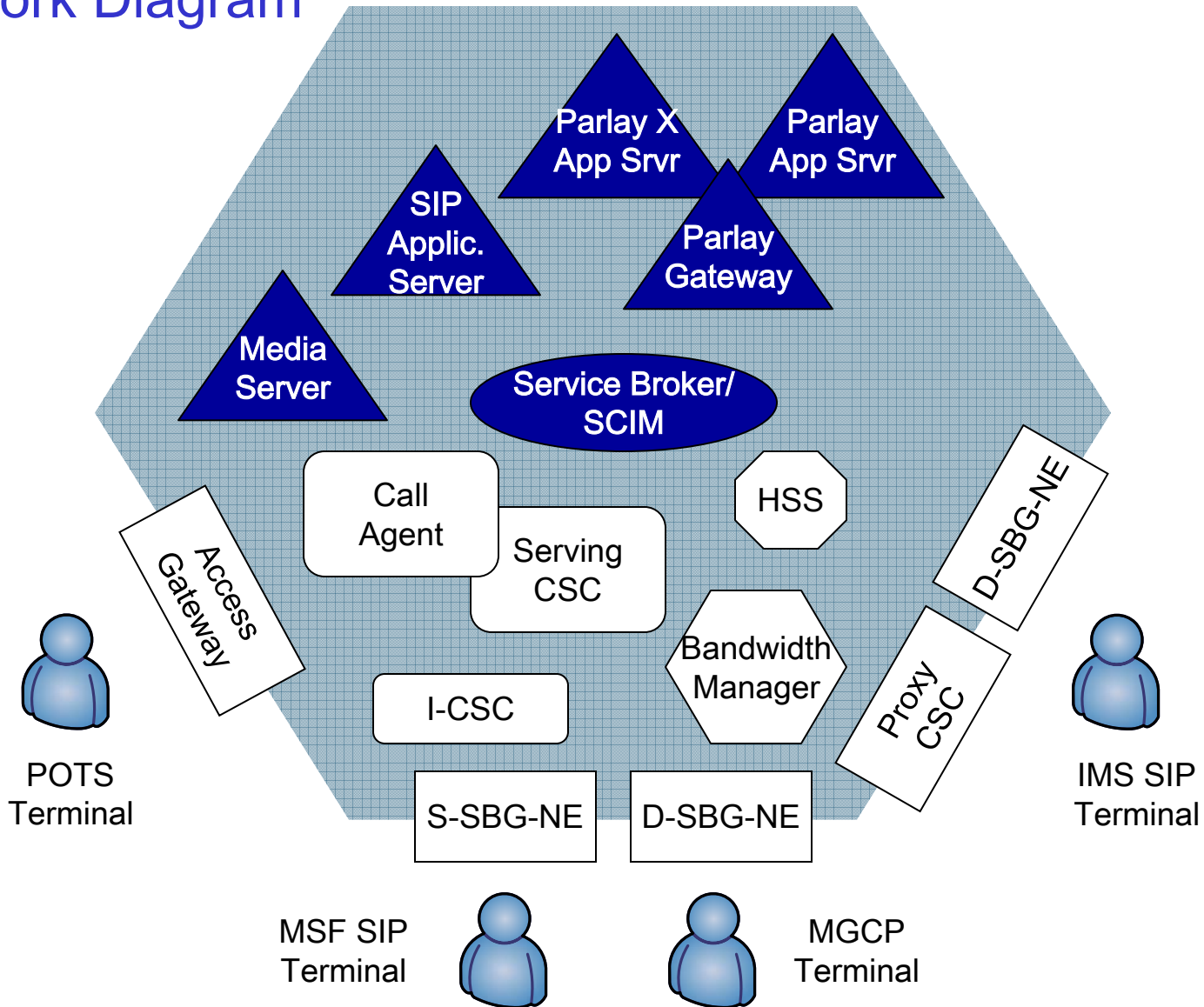

# Scenario 2

## Value Added Services

- Application Chaining:
  - IMS (S-CSC and SCIM based), MSF R2, and POTS Terminals
- Application Interaction:
  - IMS, MSF R2 and POTS Terminals
- Calling Features
  - 3-Way Calling
  - Call Waiting
  - Music On Hold
  - One Number Service
  - Originating Identity Presentation/Restriction
  - Simultaneous Ringing
  - Voice Mail
- Communication Diversion
  - Unconditional Forwarding
  - Call Forwarding on No Reply
  - Forward on Not Logged-in
  - Communication Deflection
  - Call Forward on Busy
- Conditional Service Invocation
  - For IMS, MSF and POTS Terminals
- Information Enhanced Services
  - Location-Based Directory
  - Presence Enabled Conference Calling
- Priority Calling
  - In Band PIN Authentication (with Admission Control)
  - Profile-Based Authentication
  - Challenge Response Authentication
  - Video Call with Challenge Response and Admission Control
- Third-party services
  - Click to Conference
  - Click to Connect
- Rule-based Call Handling
  - White list, black list, forwarding, announcements

# Example Service

## Priority Video Call

- Purpose
  - Allow authorized users to establish multimedia sessions with priority admission
- Key features
  - User signals need for priority with SIP Resource Priority Header
  - Parlay application authenticates user with SIP signaling and user profile information
  - Bandwidth Manager provides priority admission control

# Priority Video Call

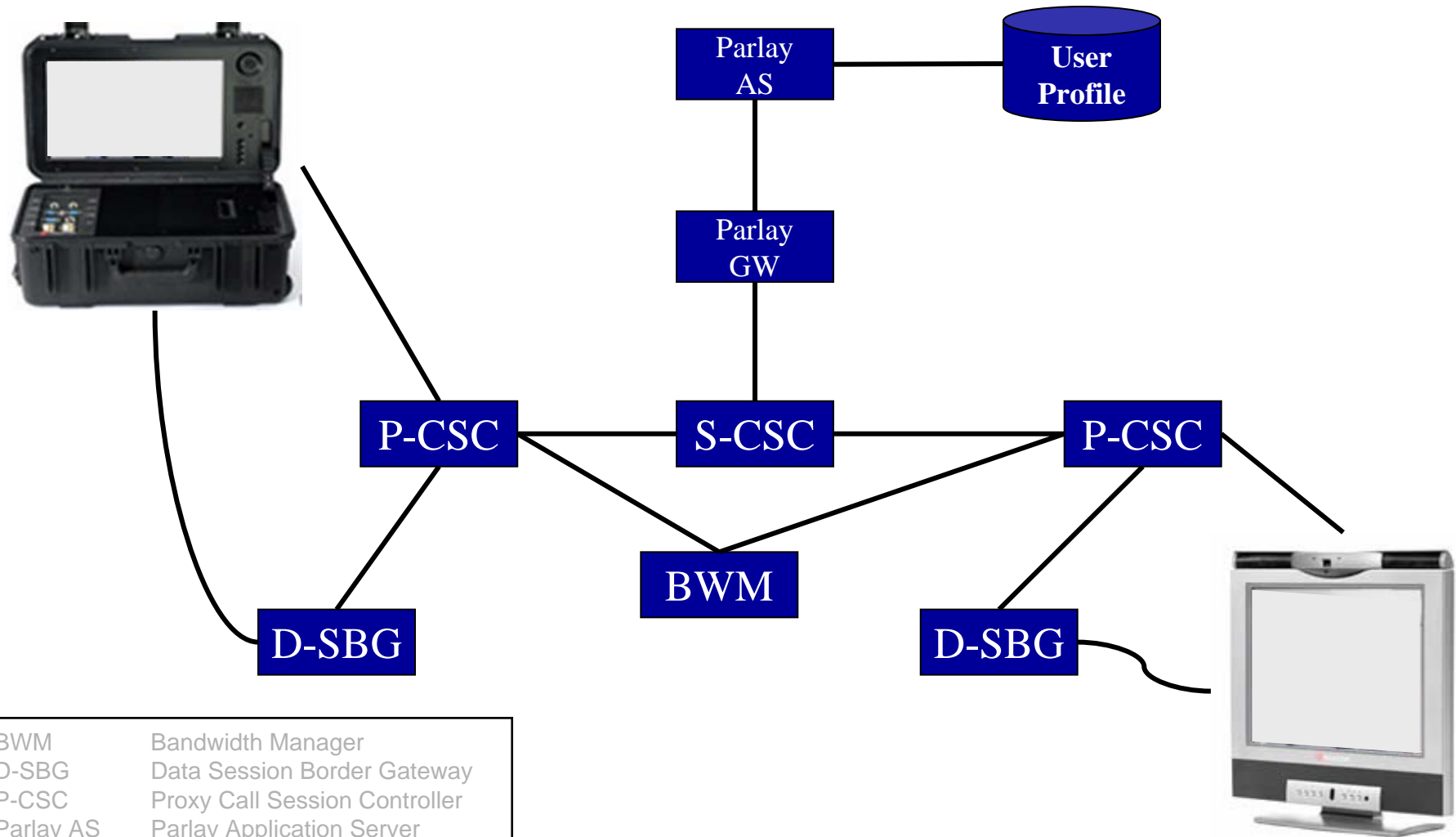

BWM	Bandwidth Manager
D-SBG	Data Session Border Gateway
P-CSC	Proxy Call Session Controller
Parlay AS	Parlay Application Server
Parlay GW	Parlay Gateway
S-CSC	Serving Call Session Controller

# Priority Video Call

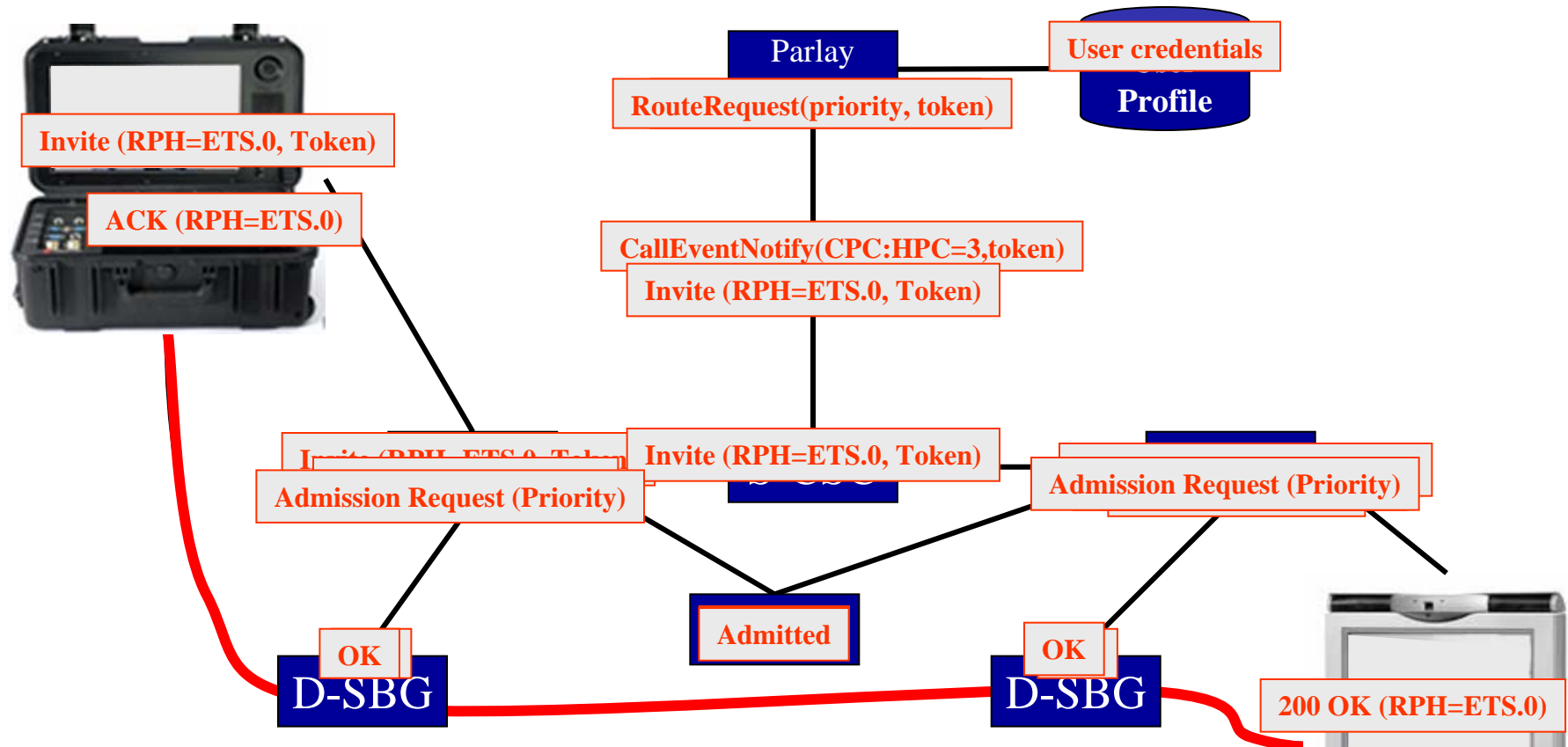

BWM	Bandwidth Manager
D-SBG	Data Session Border Gateway
P-CSC	Proxy Call Session Controller
Parlay AS	Parlay Application Server
Parlay GW	Parlay Gateway
S-CSC	Serving Call Session Controller

Call established!  
admission from  
Bandwidth Manager  
information

# Scenario 5 Network Diagram

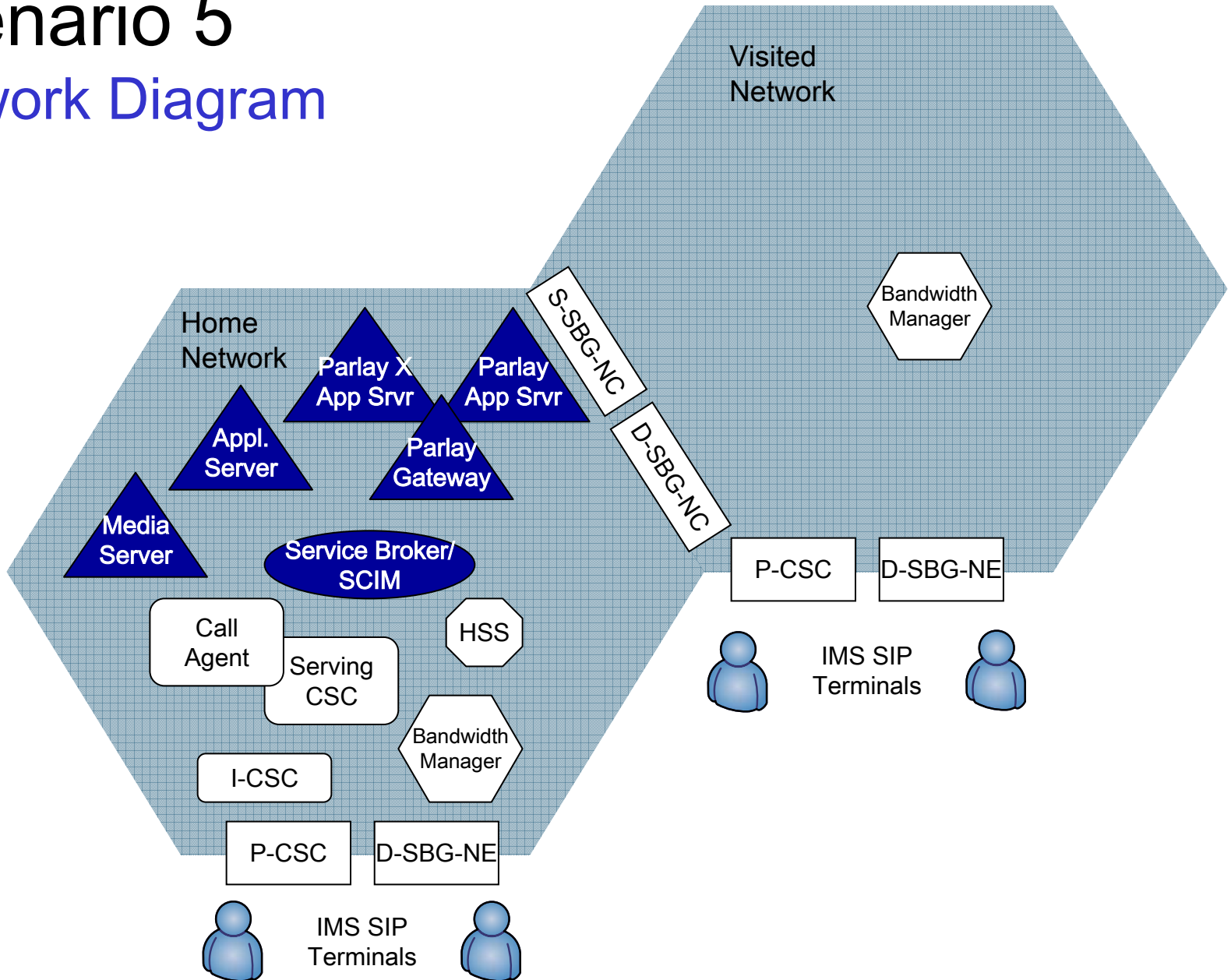

# Scenario 5

## Value Added Services – for Roamed Subscribers

- Application Chaining:
  - S-CSC based and SCIM based
- Application Interaction:
  - IMS SIP, MSF R2 SIP and POTS Terminal
- Calling Features
  - 3-Way Calling
  - Call Forwarding (no-reply, not-logged-in, on-busy, unconditional)
  - Call Waiting
  - One Number Service
  - Originating Identity Presentation
  - Origination Identity Restriction
- Conditional Service Invocation
  - For IMS, MSF and POTS Terminals
- Information Enhanced Services
  - Location-Based Directory
  - Presence Enabled Conference Calling
- Priority Calling with Roaming
  - In Band PIN Authentication
  - Profile-Based Authentication of Video Call
  - Challenge Response Authentication
- Third-party services
  - Roaming Click to Conference
  - Roaming Click to Connect
- Rule-based Call Handling
  - White list, black list, forwarding, announcements

# Example Service

## Application Chaining

- Purpose
  - Demonstrated ordered triggering of applications by the SB/SCIM in response to a single INVITE
- Key features
  - S-CSC service profile for Terminal A includes an iFC to the SB/SCIM.
  - Two application servers are triggered at the SB/SCIM
    - The SB/SCIM Service profile for Terminal A includes a scimFC for the terminating INVITE to Application Server Foo.
    - The SB/SCIM Service profile for Terminal A includes a scimFC for the terminating INVITE to Application Server Bar.
      - This scimFC is of lower priority
  - SB/SCIM resolves conflict and triggers applications in order

# Example Service

## Application Chaining

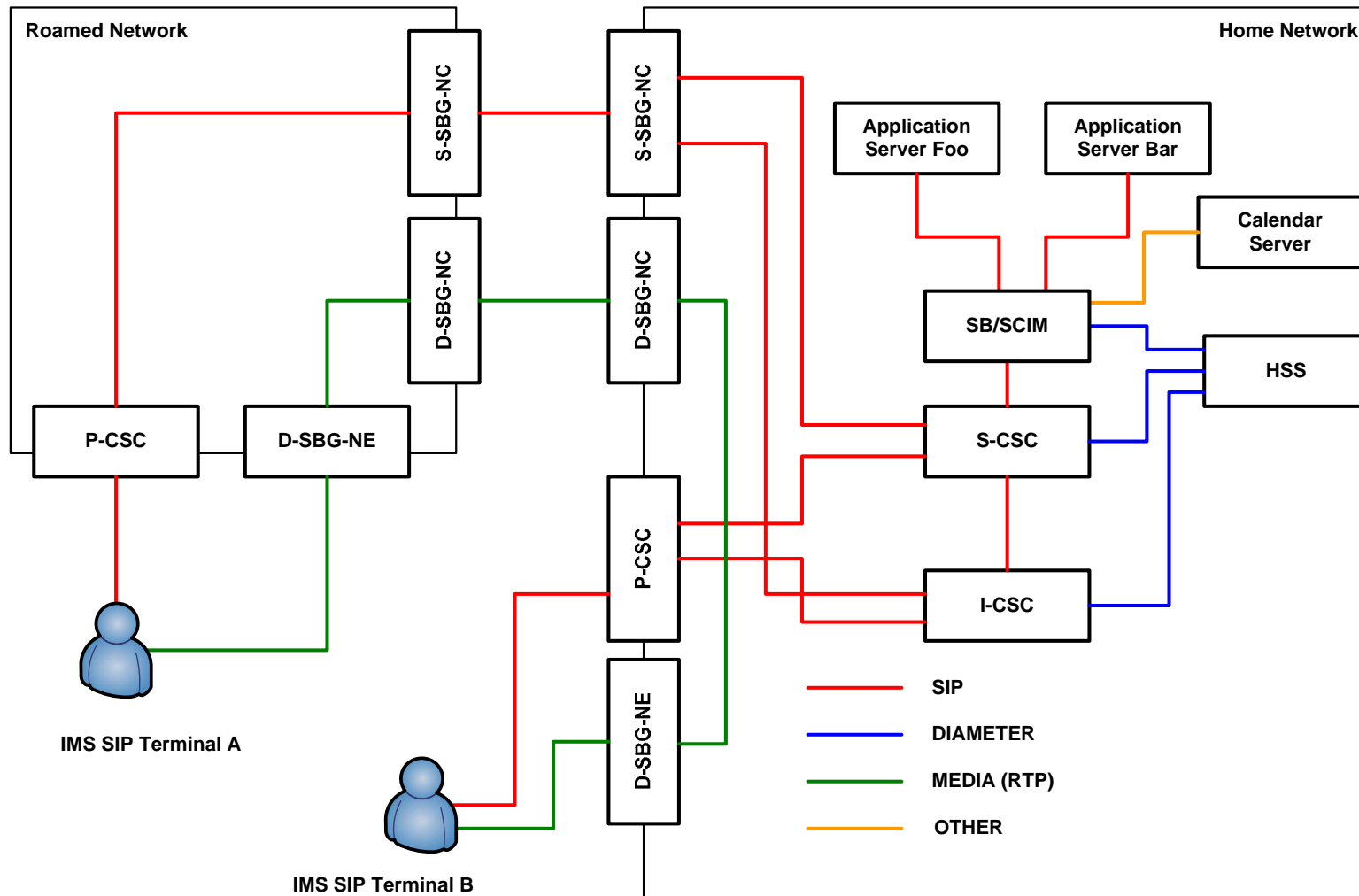

# Example Service

## Application Chaining

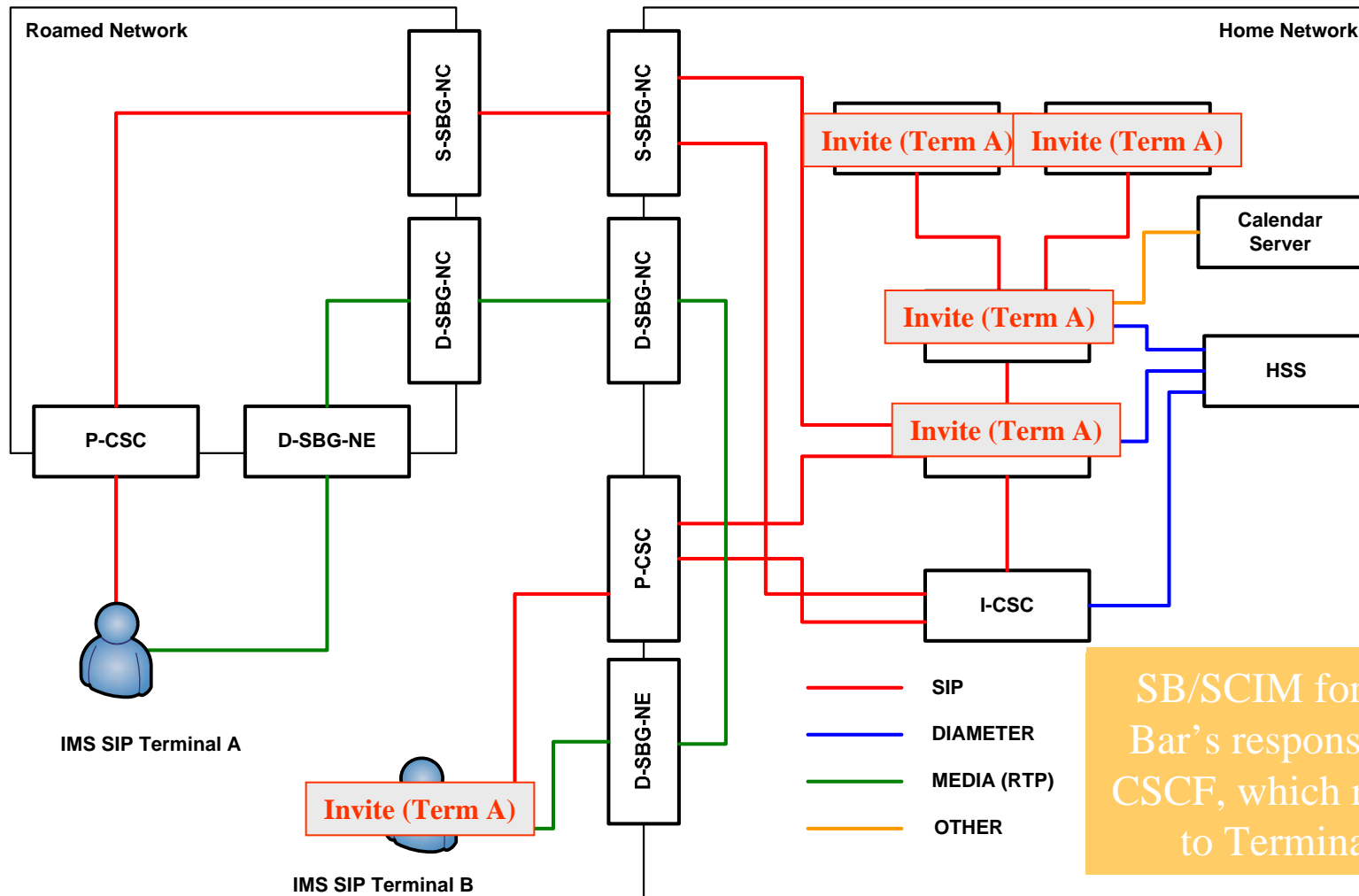

# GMI2006 Value Added Services

## Summary

- During GMI2006, over 55 test cases demonstrated advanced service capabilities in an IMS-compatible network
  - Calling features, feature interaction management, information services, multimedia, user priority
- Interoperability results across service interfaces was extremely high
  - Demonstrated interworking between multiple vendors of service platforms and infrastructure
  - Only minor implementation differences (e.g., allowed length of RecordRoute header)

Advanced Services for Roaming IMS Endpoints