



MSF GMI 2006

Deep dive QoS

Olov Schelén, CTO

MSF presentation at VoN San Jose

2007-03-22

- ▶ Session control through SIP
 - The basis for network operators supporting carrier grade voice and multimedia services

- ▶ 3GPP IMS and the ITU-T and ETSI Tispan NGN
 - These standards define an architecture supporting SIP based session control, roaming and accounting for fixed and mobile IP networks

- ▶ Resource and Admission Control functions (RACS/RACF) and Policy and Charging functions (PDF/PCRF)
 - Central in these architectures are the
 - Resource and Policy based service control (QoS control)
 - These functions are essential in providing accountable services both for network operators and for independent service providers

ITU/ETSI NGN Standards

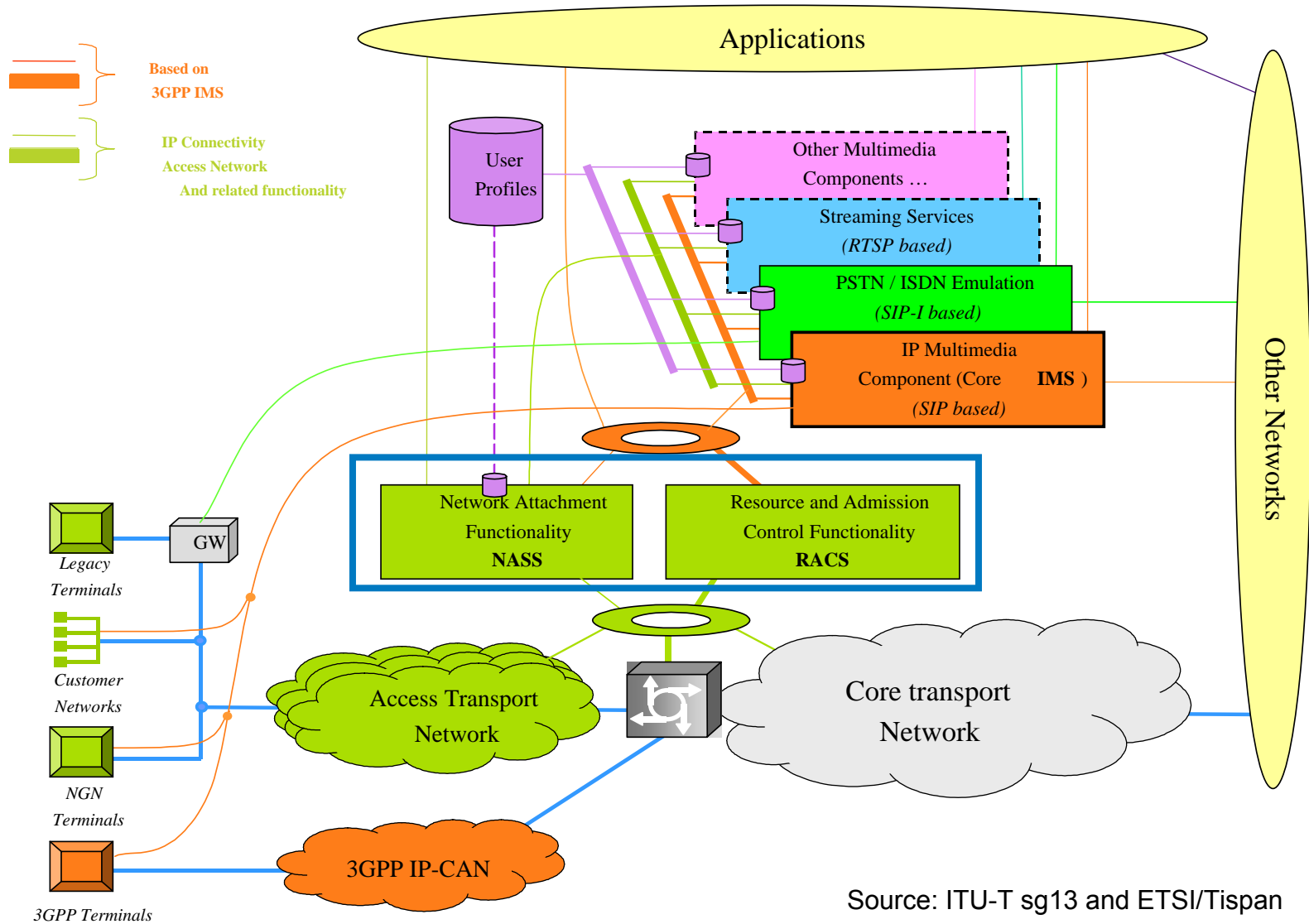

Source: ITU-T sg13 and ETSI/Tispan

NGN networks

ITU-T NGN/IMS Network Architecture

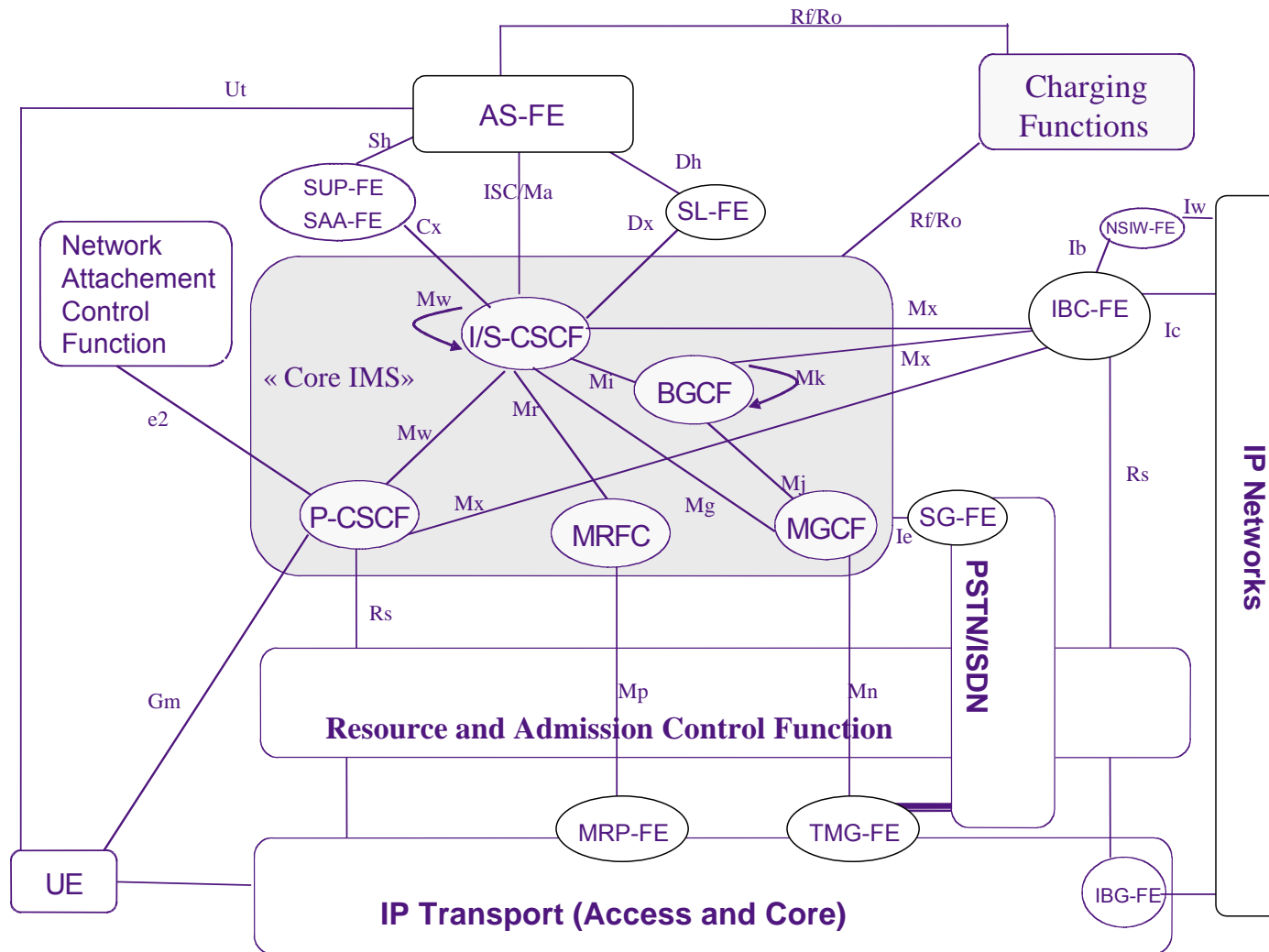

NGN networks

ETSI/TISPAN Release 1 Network Architecture

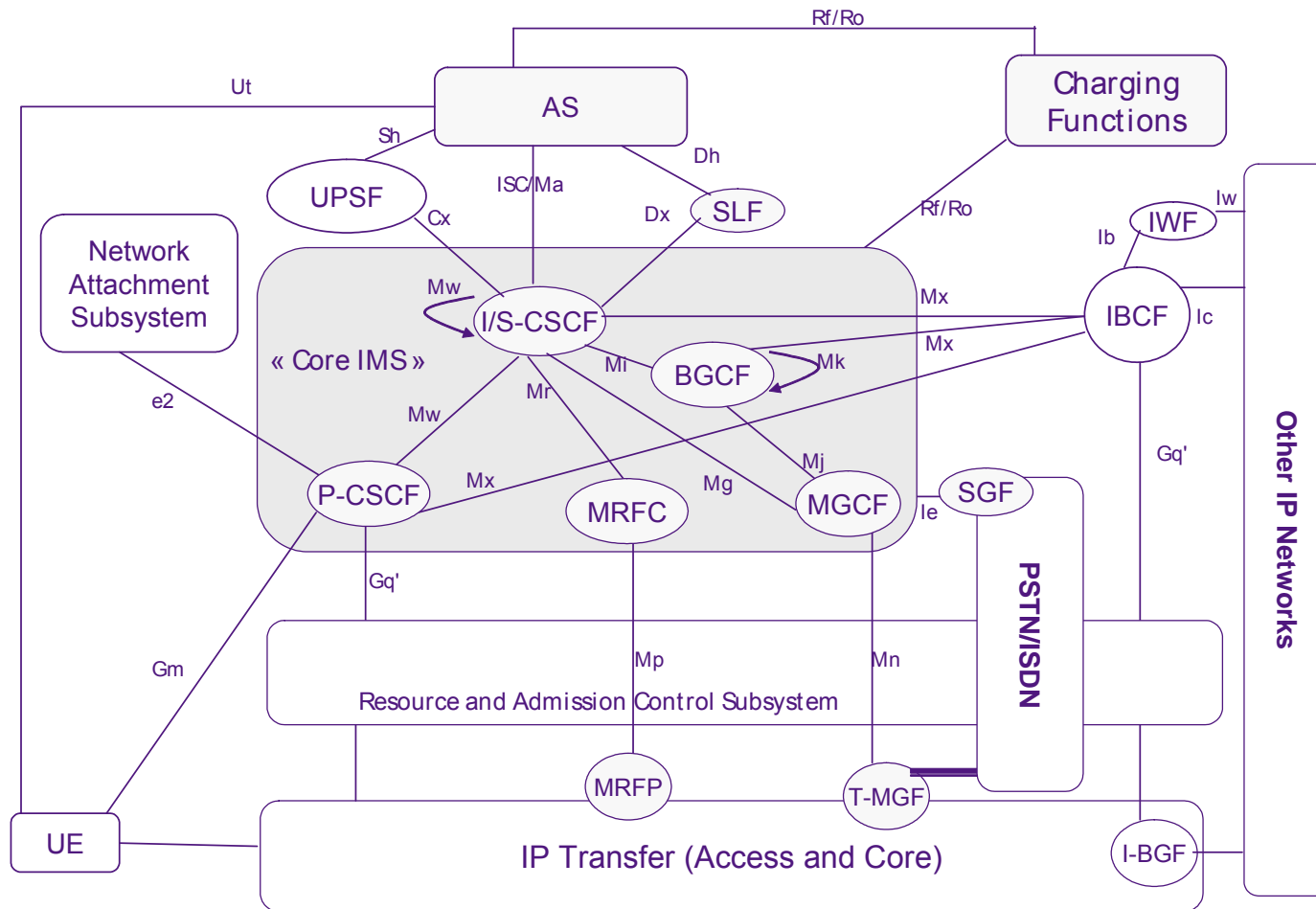

- ▶ SIP Application Servers
 - Hosts and executes SIP based IP Multimedia Services
- ▶ Call Session Control elements (P-/I-/S-CSCF)
 - P-CSCF – First point of contact for signaling (Inbound/outbound proxy)
 - I-CSCF – Entry proxy at edge of administrative domain
 - S-CSCF – Session Control server
- ▶ HSS/SLF
 - Repositories for subscriber information
- ▶ BGCF/SGW/MGCF/MGW

Media transport and Signaling elements for IMS/PSTN interworking

 - BGCF – SIP server for routing calls addressed to circuit switched networks
 - SGW – Signaling conversion for interfacing with CS networks
 - MGCF – Call control protocol conversion and media conversion controller
 - MGW – Media conversion element

3GPP IMS Standards (Rel 6 & 7)

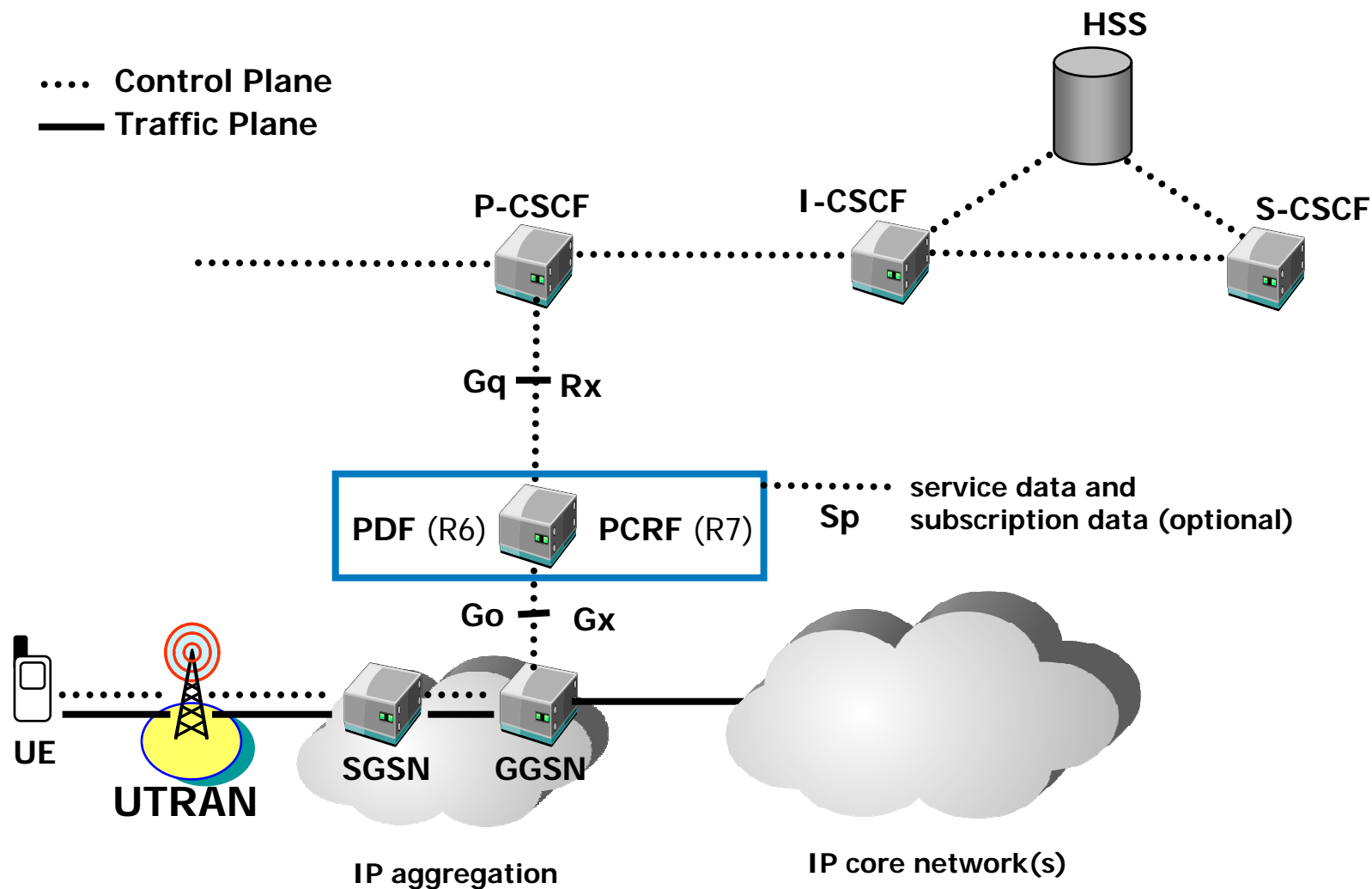

▶ IETF

- The mother of protocols used in the IMS/NGN
 - SIP, Diameter, Megaco/H.248, COPS, (Radius, LDAP), etc
- Policy Information Model + PDP and PEP

▶ DSLF

- Policy server / network resource control

▶ Packet Cable

- PCMM policy server

▶ MSF

- Bandwidth Manager

Providing physical architecture
State of the art interoperability tests

- ▶ Grade-of-service for IMS/NGN must be at least as good as legacy (telephony, cable-TV, etc.)
 - Interactivity is a key driver for IP services and user behaviors are difficult to predict
 - Relative contention points due to technology or cost, e.g. in access links, at backhaul aggregation, at interconnect points

- ▶ IP network to provide managed services with low operational complexity
 - A few classes of service in network to serve many applications, business units and ASPs

- ▶ Speed to market for services
 - Differentiated services packages (consumer and enterprise)
 - Service equivalence between competing ASPs

The RACS of ETSI TISPAN R1

- ▶ Gq': QoS request
 - Diameter based
- ▶ e4: Network attachment
 - Policies, resources, dynamic IP addr
 - Diameter based
- ▶ Ia: Border Gate Control
 - H.248 based
- ▶ Re: IP Edge control
- ▶ Ra: Upstream control
- ▶ Rc: Resource/topology map

▶ NOTE: per-session (per flow) admission control

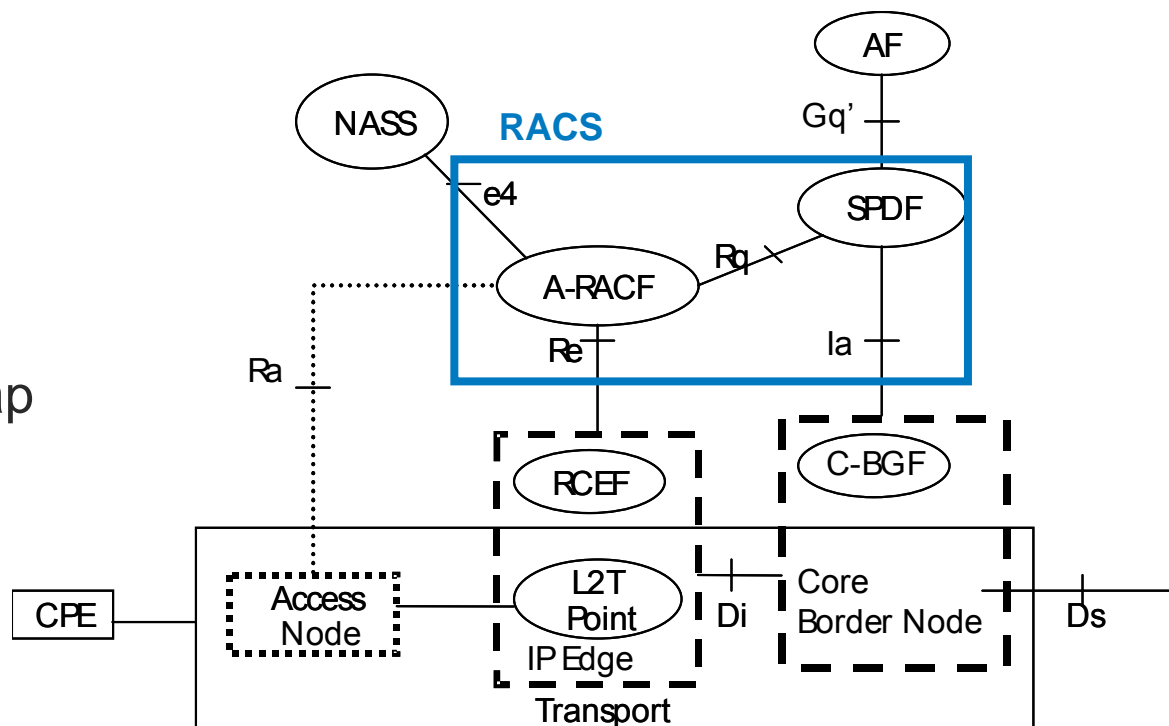

ITU-T RACF QoS solution architecture

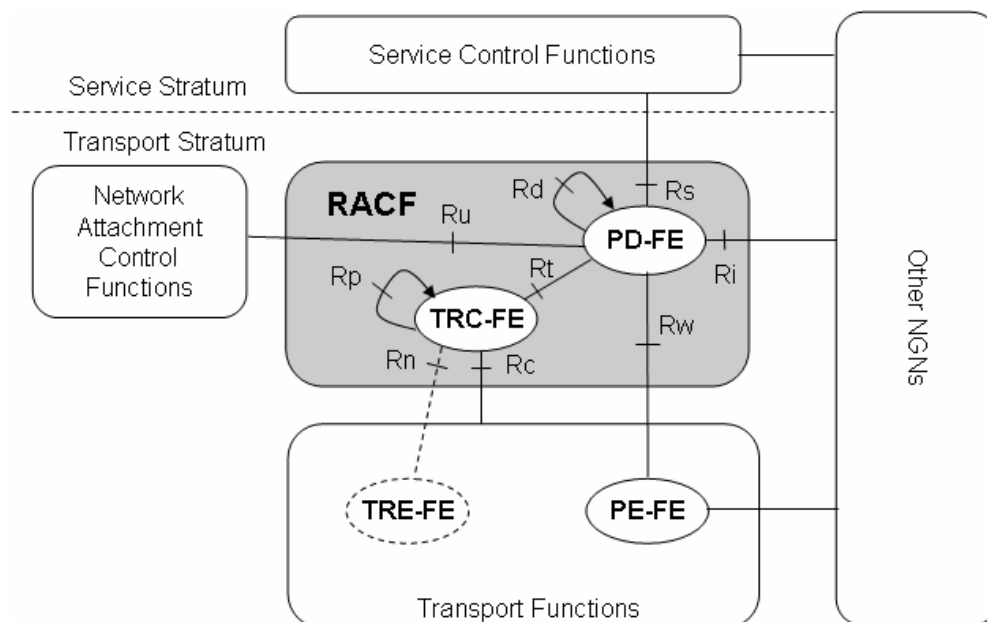

- ▶ The overall function and the interfaces of RACF are similar to ETSI Tispan
 - Added interdomain interface (R_i) for the PD-FE
- ▶ Internally there is a different functional composition

- ▶ **Separate network & services**
 - The success of the Internet for data services, streaming and conversational best-effort services shows that the model of separating network and services is right

- ▶ **Lessons for IMS/NGN**
 - Therefore it is essential that the IMS/NGN does not break this model by introducing unnecessary control of network resources in application servers, or application specific control in network elements

- ▶ **Clear separation of functions in the physical instantiation**
 - RACS/PDF in Independent Bandwidth Manager (BM)
 - Multi-purpose Resource and Policy based Admission Control
 - Multi-service: Independent applications, IMS and non-IMS
 - Multi-technology: Independent network

PSTN switch architecture

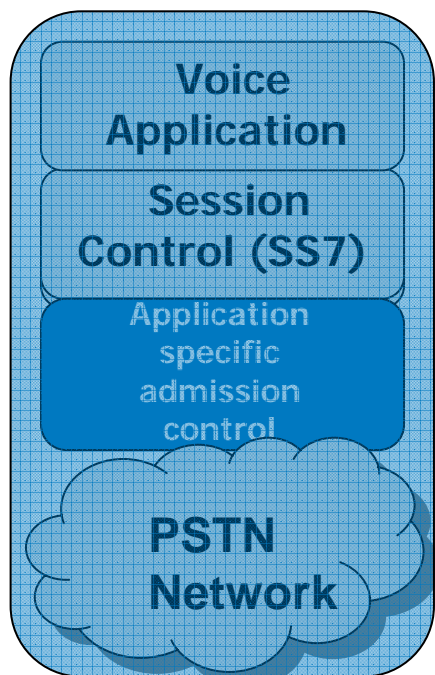

QoS stovepipes

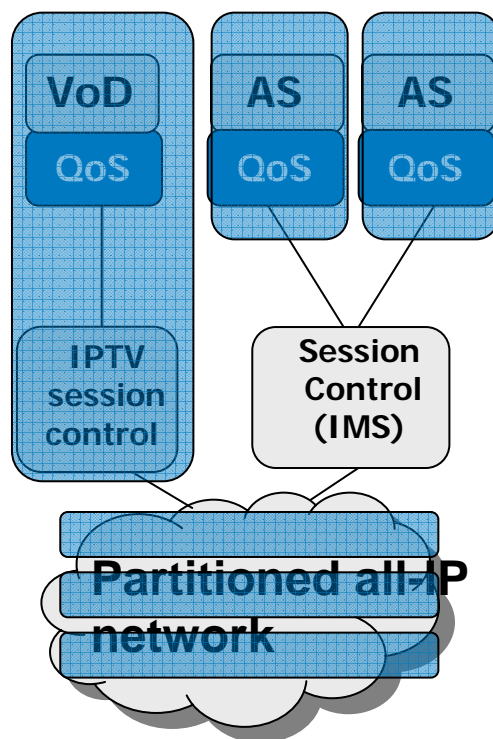

Layered architecture

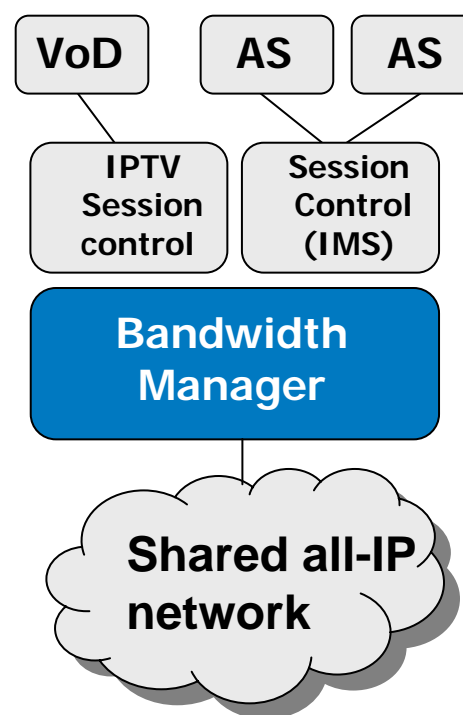

The Bandwidth Manager, a common capability in a Service Delivery Platform

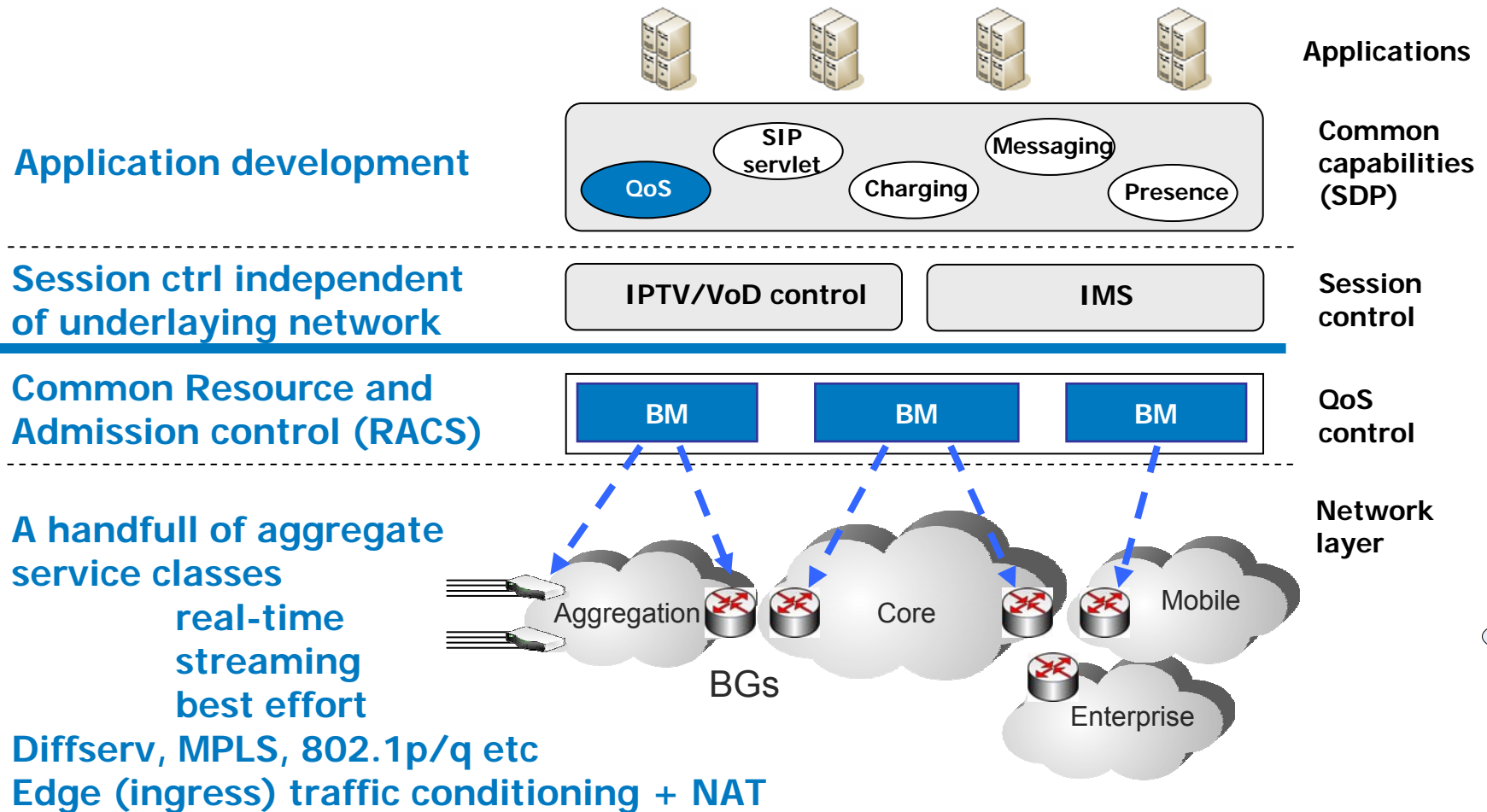

▶ Practical validation of the converged IMS architecture

- 5 sites worldwide

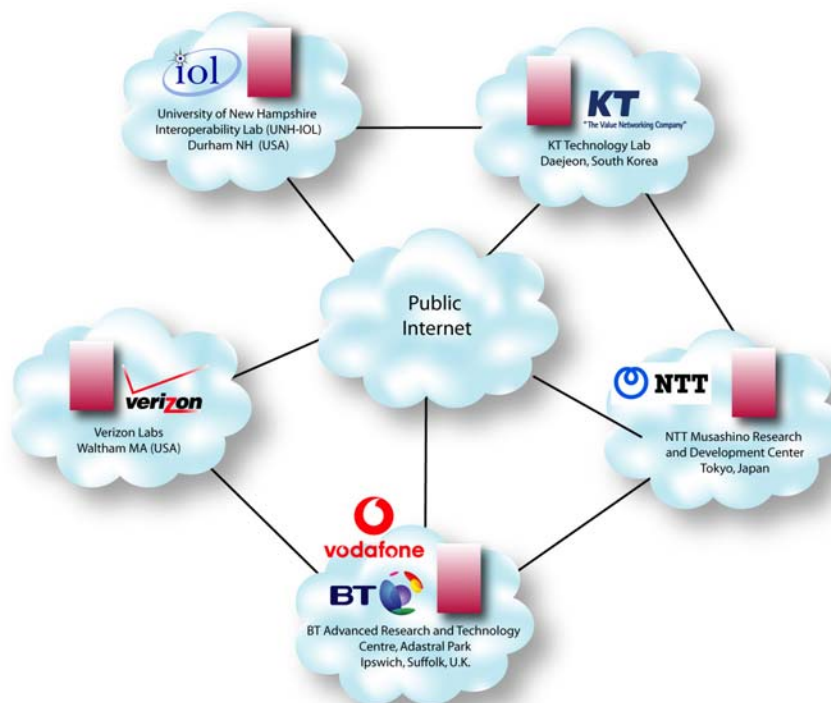

▶ Demonstrating

- Enforced QoS using Bandwidth Manager and Session Border Gateway
- Service brokering and third party applications
- Priority call interworking between NGN and PSTN
- IP carrier interconnect

MSF R3 Architecture

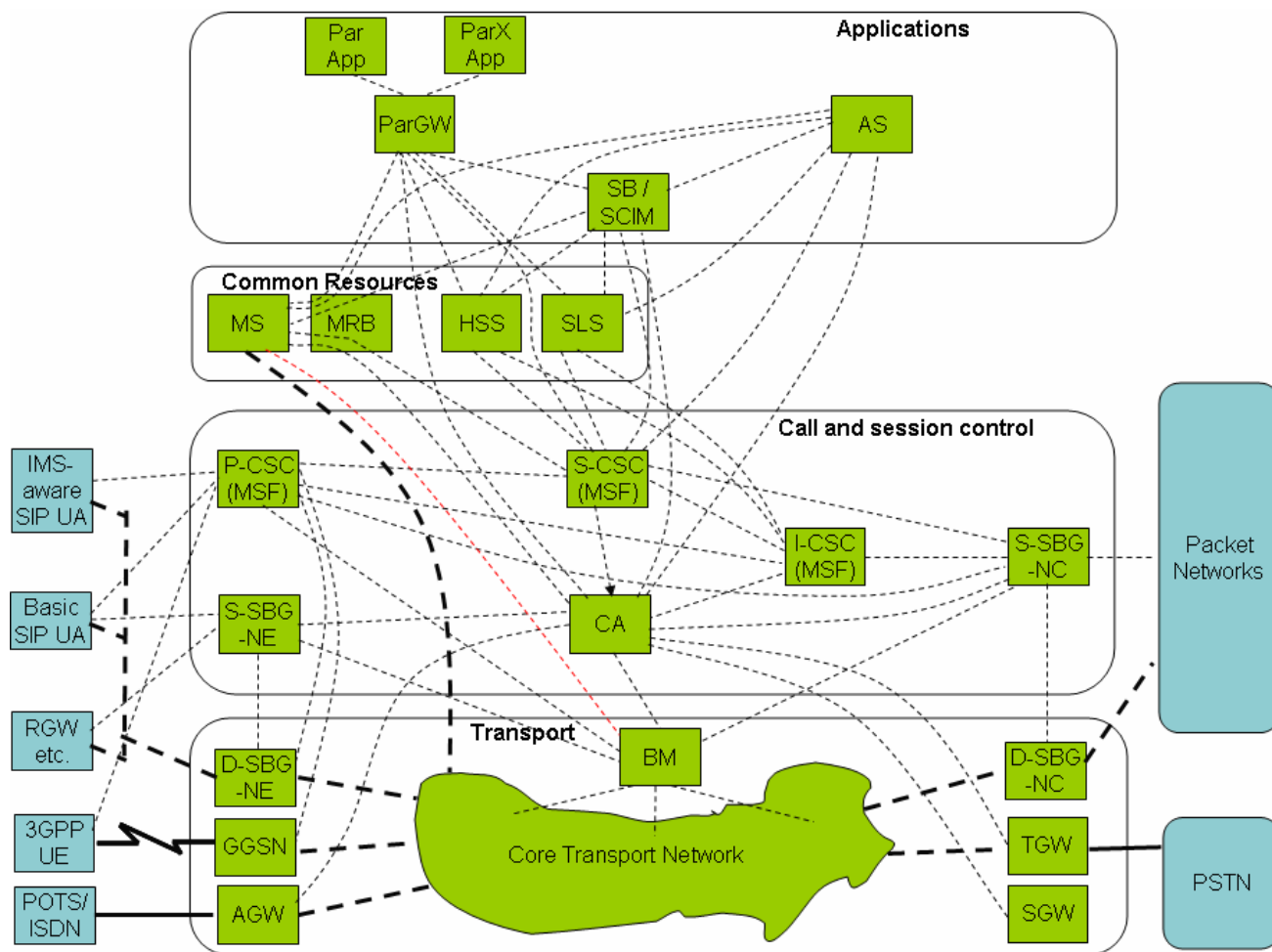

- ▶ SIP services, IMS based and non-IMS (traditional Call Agent)

► MSF Release 3 QoS solution architecture

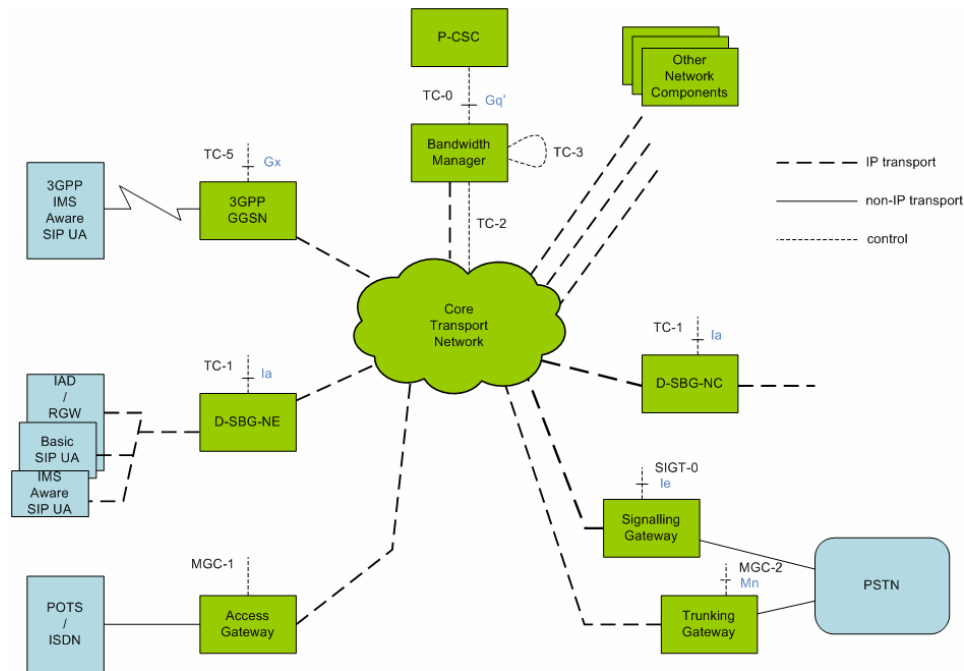

► IMS/NGN alignment

- TC-0 ETSI Diameter Gq' (Derived from 3GPP Gq)
- TC-1 H.248/Ia
- TC-2 Topology Acquisition (Routing protocols + SNMP)
- TC-5 3GPP Diameter Gx

MSF Release 3 QoS solution architecture

► MSF Release 3 QoS solution architecture for GMI 2006

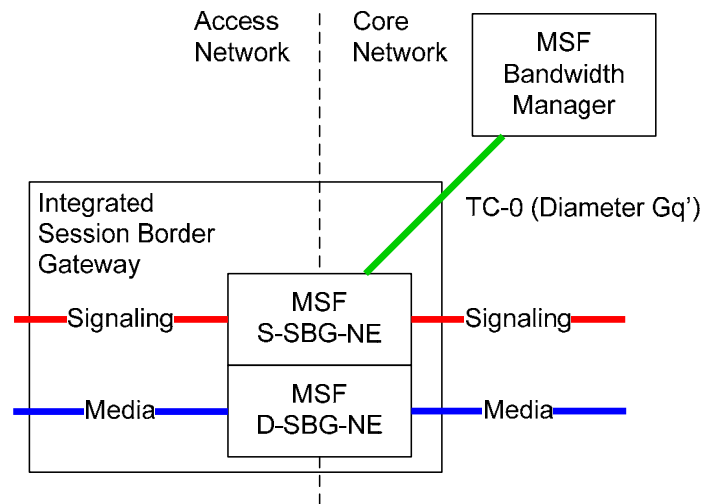

- SBG participates in SIP signaling (P-CSC(MSF) or non-IMS SIP Proxy)
- SBG reserves core network resources from Bandwidth Manager (CAC)
- Bandwidth Manager keeps track of core network resource usage
- SBG performs DiffServ marking of admitted media service flows

- ▶ Independent Bandwidth Manager (BM) in the physical architecture
- ▶ Interoperability between P-CSC and BM
 - Diameter-based protocol (IA based on ETSI Gq', 3GPP Gq)
 - Also tested a SIP interface to BM (i.e. BM as SIP proxy)
- ▶ Interoperability between S-SBG and BM
 - COPS based
- ▶ QoS was verified
 - BM handling bandwidth overload situations
- ▶ Priority call preference was verified
 - Resource Priority Header was used
 - Prioritized in admission decision

Example: Commercial case 1

Wireline IMS, Multipurpose Bandwidth Manager (RACS)

▶ Background

- Broadband offer with value added services
- VoIP & Video Telephony first step, IPTV/VoD second step
- Issue: guarantee service availability and QoS

▶ Environment

- DSL access
- ATM or Ethernet aggregation

▶ Solution

- SBC interfacing BM
- CLF interfacing BM
- Provisioning into BM

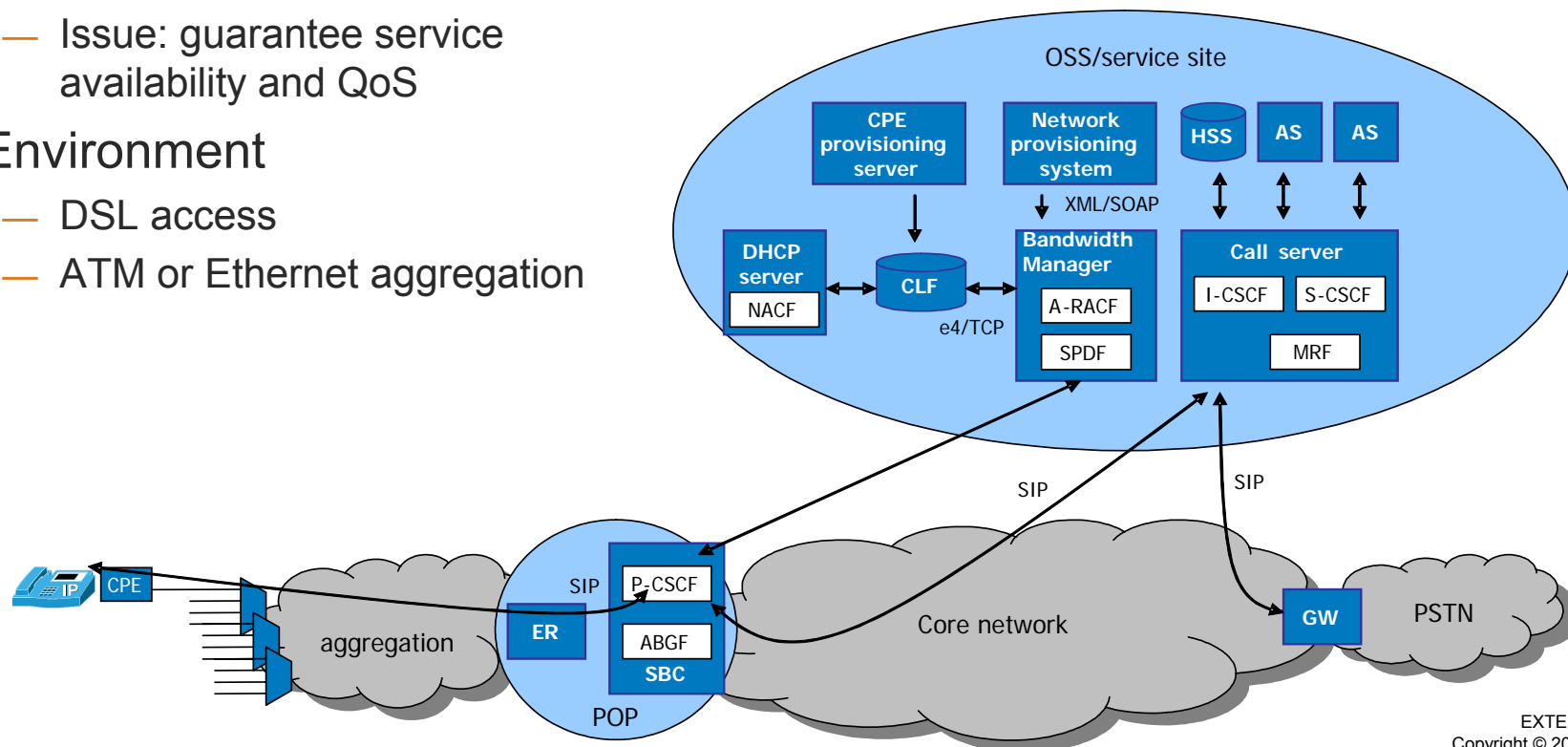

Example: Commercial case 2

Wireline IMS, Multipurpose Bandwidth Manager (RACS)

▶ Background

- Broadband offer with value added services
- VoIP & Video Telephony first step, IPTV/VoD second step
- Issue: guarantee service availability and QoS

▶ Environment

- DSL access
- ATM or Ethernet aggregation

▶ Solution

- S-CSCF interfacing BM
- CLF interfacing BM
- Provisioning into BM from OSS/CLF

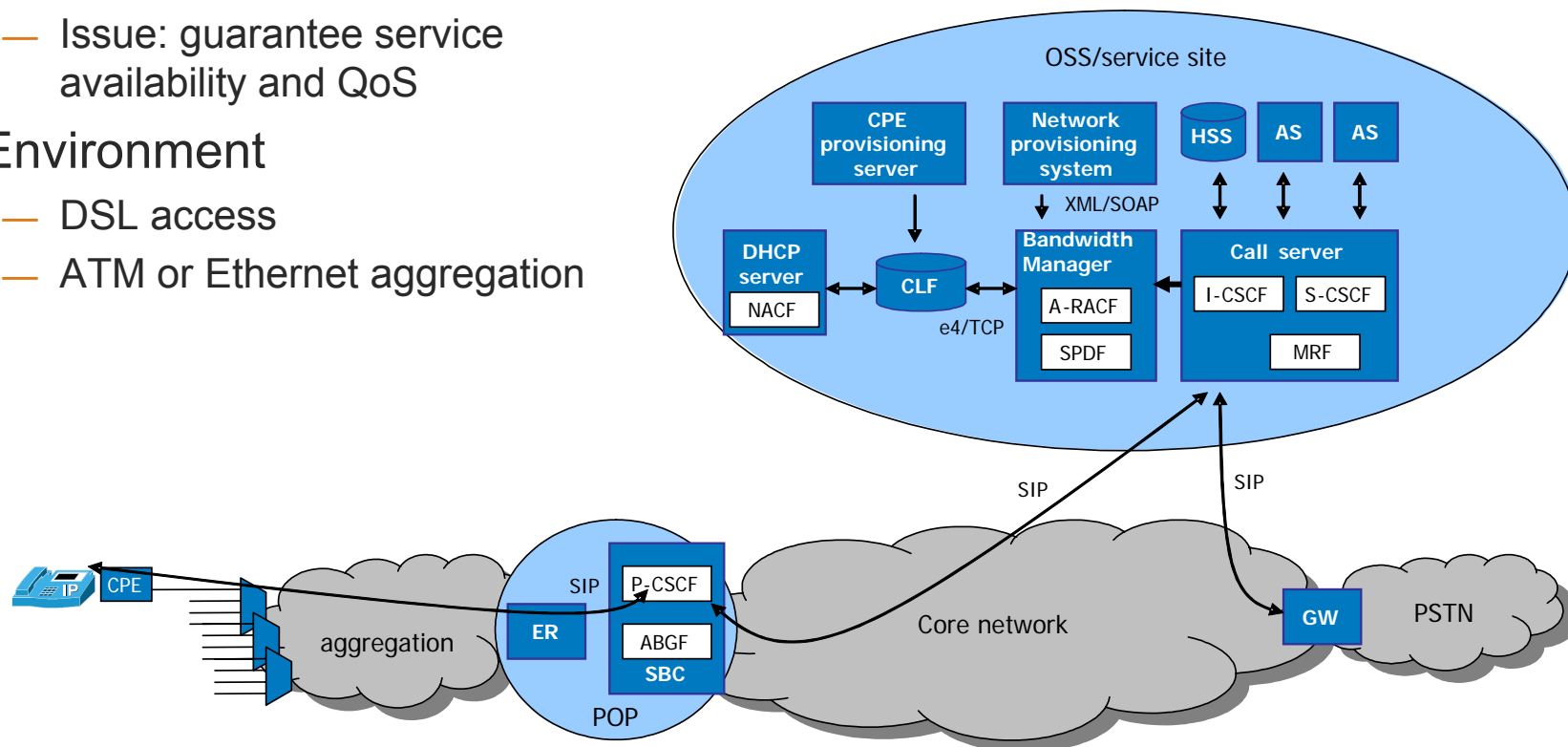

Example: Commercial case: Non IMS VoD Multipurpose Bandwidth Manager (RACS)

▶ Background

- Video on Demand
- QoS control is a must

- Next phase: Network transformation to NGN/IMS
- end-to-end QoS

▶ Environment

- Metro Ethernet (FTTX) or DSL
- IP/MPLS core

▶ Solution

- Video middleware interfacing BM
- Aggregation Gateway/Edge router
 - RADIUS (CoA) or COPS-PR interfaces
- End-to-end control solution

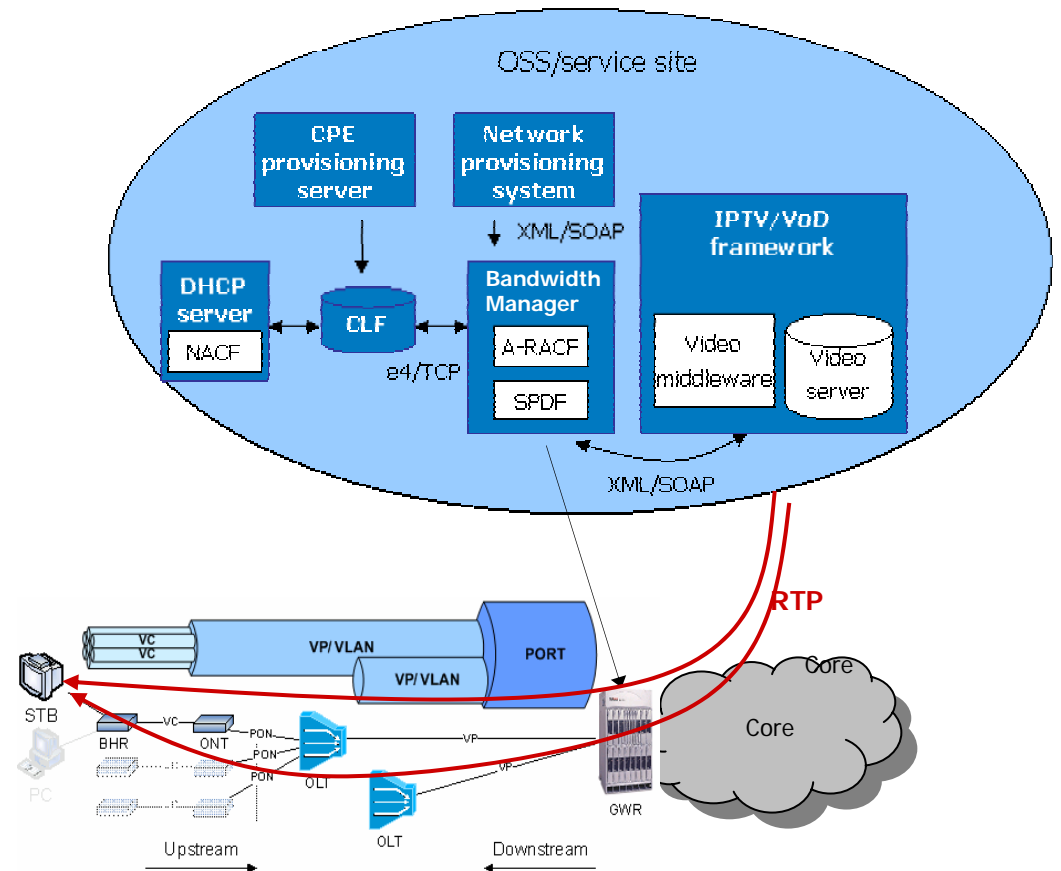

MSF Current discussions

- ▶ Further alignment w/ ITU-T, 3GPP and ETSI/TISPAN defining physical realizations of functional architectures
- ▶ Refining Policy Control
- ▶ Incorporating access networks in the architecture
- ▶ Web services 2.0 and IPTV

► MSF Release 4 QoS solution architecture?

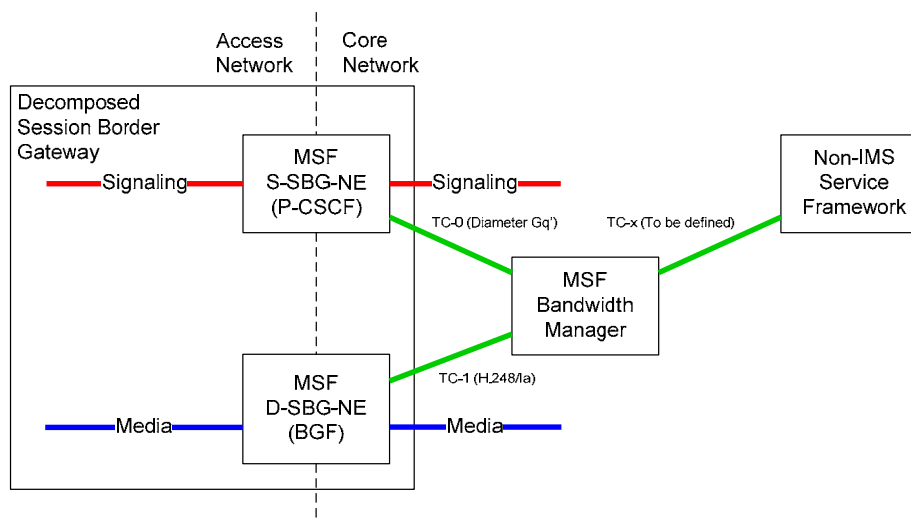

- Accommodates both IMS and non-IMS services
- Bandwidth Manager serves all service frameworks and can perform gate control, NAT-PT and policing to any Application Server
- SBG participates in SIP signaling as P-CSCF
- SBG can be either integrated or decomposed



Operax AB
Tegeluddsvägen 92
S-115 28 Stockholm
Sweden

Erik Lundgren and Olov Schelén
CTO office

Phone: +46 8 410 239 00

Fax: +46 8 410 239 01

E-mail: info@operax.com

www.operax.com

Thanks!

operax

Network Service Quality