

A Multiservice Networking Architecture for the 21st Century

A Summary of the Multiservice Switching Forum's Release One Architecture

MSF-ARCH-001.00

1 INTRODUCTION

The Multiservice Switching Forum (MSF) was founded in 1998 by leading service providers and telecommunications equipment vendors. The initial goal of the MSF was to define a generic architecture for the next generation distributed switches and routers and to identify the open interfaces and standards required in support of that architecture. Since then the goal has evolved to define a framework architecture that would allow support of overall multiservice networking including applications, APIs and network and service management aspects. In addition to the architectural work, the MSF will specify Implementation Agreements (IAs) that define the overall reference architecture, the functional components and interfaces of Multiservice Switching Systems (MSS) and the requirements and protocol specifications of the interfaces between functional components of an MSS.

2 THE MSF ARCHITECTURE

2.1 Architecture Objectives

The MSF Architecture provides support for the following business goals:

- Allowing procurement of modular and reusable subsystems that interconnect via standard interfaces to provide the functionality of an MSS
- Facilitating vendor, carrier, or third party development of application software, as well as exploiting commercially available computer hardware and software, thereby reducing time to market for new technologies and services.
- Reducing operational complexity by providing standardized modular systems and fully automated remote management capabilities.
- Support partitioning of a common physical network into logically separate virtual networks.
- Supporting multiple services and applications (each potentially controlled via its own signaling and control protocols) over a common MSS infrastructure.

The MSF Architecture also includes support of the following technical objectives:

- Enable service and application implementations to be independent of changing transport types and technologies, while enabling common trunking of all services between MSSs.
- Separate the control, switching, adaptation and management aspects of a MSS.
- Enable placement of service, application and transport/media interworking at the network edge.
- Support integrated voice, video, data, and multimedia switching and call processing.
- Scalable across a broad range of port counts, aggregate bandwidth, and transaction rates while supporting a broad range of QoS capabilities.
- Support efficiency and flexibility of configuration including remote placement of system components.
- Support new control, switching, adaptation, and management functions without requiring changes to the defined intra-switch and external interfaces and protocols.

- Provide transparent access to enhanced connectivity and value added network services from any port.

2.2 Scope of the Architecture

A multi-plane system model has been selected as the basis of the multiservice networking architecture. Within each plane logical components are defined in support of the functionality and information flows that have to occur within that plane and across the plane boundaries. The architecture employs a logical model, clearly identifying the areas where IAs are necessary, it is expected that the standards on which these IAs will be based, will be developed by the traditional standards bodies.

An essential characteristic of the Architecture is its flexibility in terms of the technology chosen to implement functionality of each plane. New technologies are allowed to evolve independently from each other in all three planes.

Within the vision of multiservice switching, controllers in the Control Plane can share the resources of the Switching Plane and of the Adaptation Plane. By applying service management and policy mechanisms to switch resources, they can be separated or combined as required to support the network's applications. One important effect of the grouping of resources is the creation of virtual switches, each of which may be paired with a controller in the Control Plane.

Figure 1 illustrates the Adaptation, Switching, Control, Applications and Management Planes of the architecture.

- The Adaptation Plane supports the physical interface to a user or another network element.
- The Switching Plane supports the actual switching fabric by which physical interfaces are connected.
- The Control Plane provides the generic capability to manage network service events and provides control over both the adaptation and Switching Planes. Standard protocols are used in communicating between the Control Plane and the Switching/Adaptation Planes.
- The Application Plane provides services that use the capabilities of the Control Plane. It also provides enhanced services that control the services realized within the Control Plane.

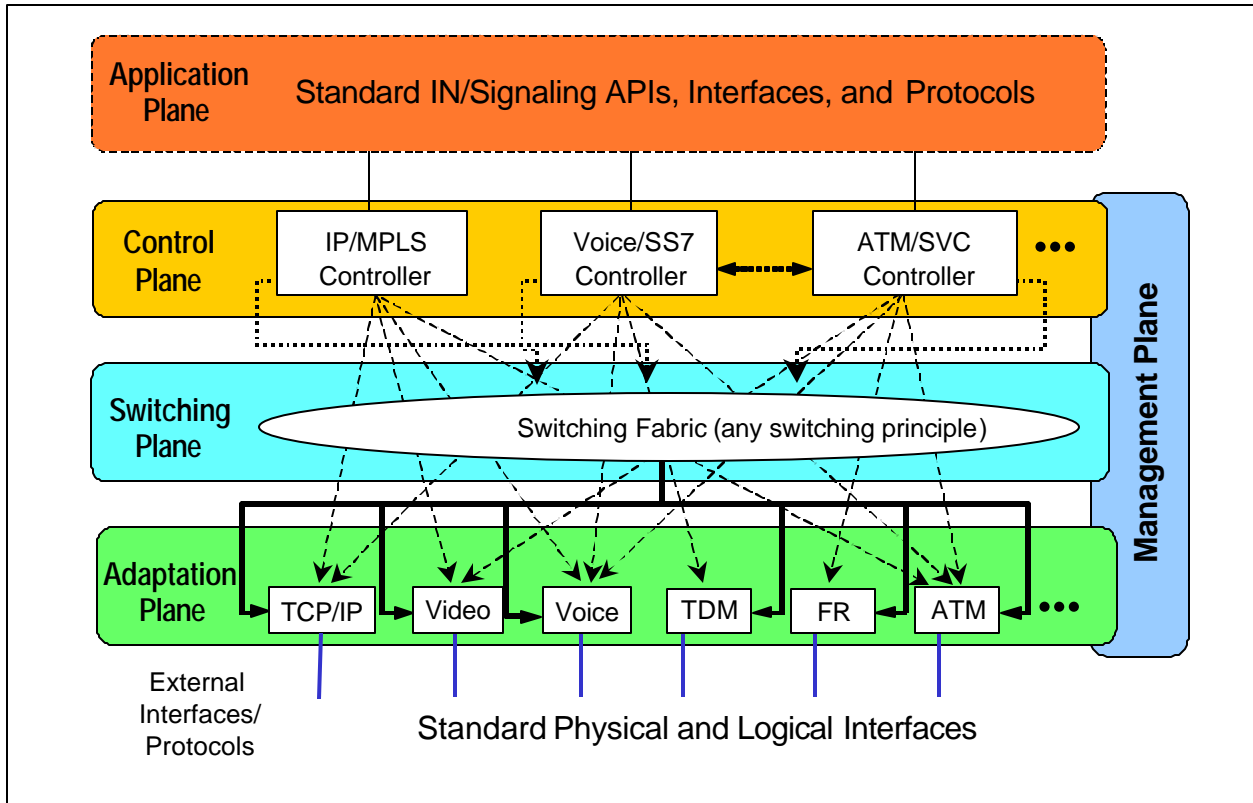
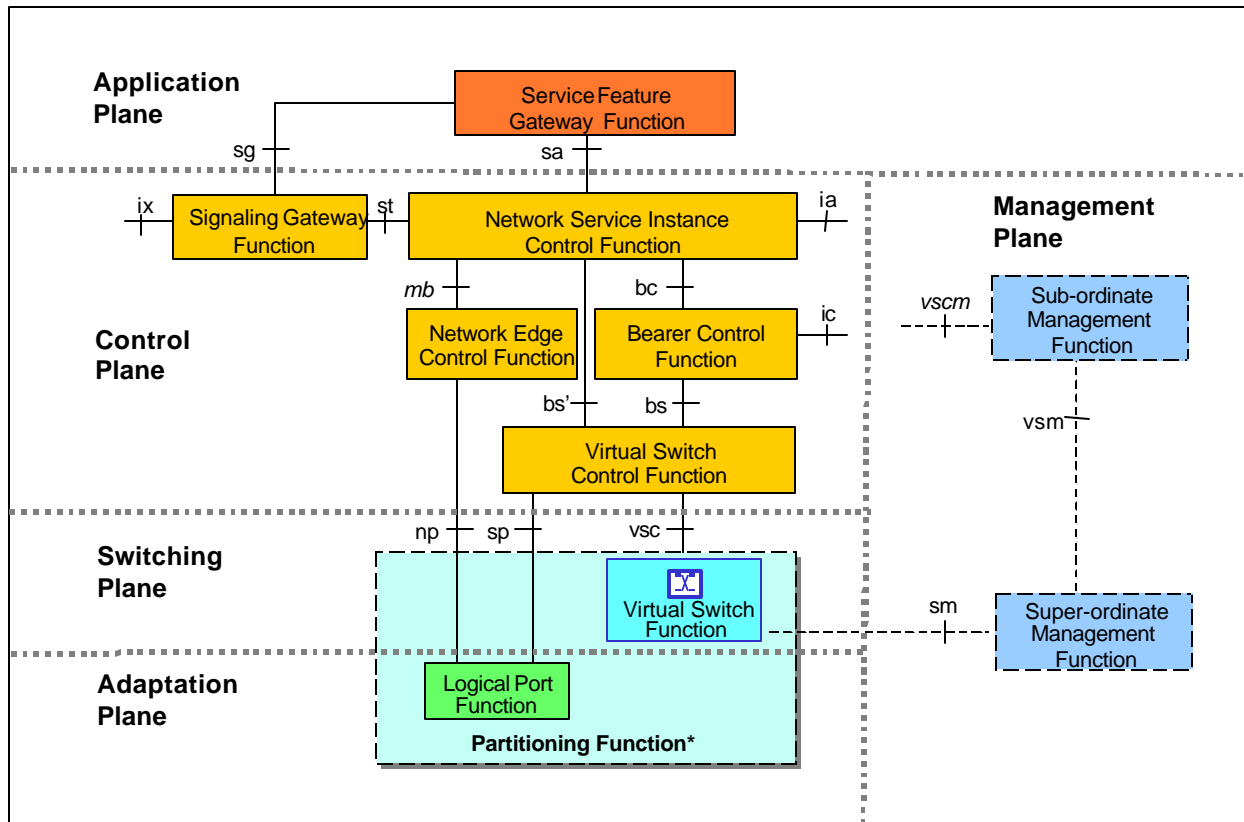

Figure 1 Scope of the Multiservice Switching Forum Architecture

2.3 Functions and Definitions

This section provides descriptions of the planes, the functions within each plane, and the reference points. Figure 2 identifies functional groupings within the MSF System Architecture. Reference points are defined between the identified functional groupings.



Notes:

- Italicized reference points are not considered open reference points for release 1.
- Bearer transport reference points are not shown.
- - Management functions overlaid on functional architecture
- * The Partitioning Function maintains partition integrity between partitions of a partitioned entity.

Figure 2 Reference Architecture Corresponding to Functional Definitions

2.3.1 Adaptation Plane Description and Functions

The Adaptation Plane is responsible for providing access to a large variety of UNIs, SNIs and NNIs that a MSS may support. Currently the adaptation plane contains a single functional component, the Logical Port Function (LPF). Typical functions of the Adaptation Plane are:

- Processing real-time services (such as voice and video) and non-real time services (such as file transfer) into bit patterns and protocol formats for the Switching Plane to process and transport between ports.
- Providing service-specific functions that do not directly alter user data on the interface. For example, classification and scheduling of the media stream to provide the required QoS, as well as policing and shaping the media stream to ensure that it adheres to the negotiated traffic contract.
- Replicating cells for point-to-multipoint connections.

Adaptation Plane resources may either be dedicated to a single controller (e.g. VPI/VCI values of an ATM port), or shared between controllers (e.g. buffers).

2.3.1.1 Logical Port Function (LPF)

Each LPF instance provides the necessary media mapping and service specific adaptation functions related to the incoming media stream. It maps an external media stream to the internal media stream routed by the specific switching function to another logical port or another functional entity. An LPF utilizes the set of physical resources (e.g., echo canceller) allocated by the Network Edge Control Function (NECF) to perform a defined adaptation task. For associated signaling (e.g., ISDN, UNI, FR), the Signaling Gateway Function (SGF) is tightly related to the LPF in order to relay signaling to the associated control complex.

Management assigns an LPF to a Partition using the sm reference point.

2.3.2 Switching Plane Description and Functions

Functions of the Switching Plane within a MSS include:

- Providing basic cross-connect functionality between logical ports
- Forwarding user information using labels/tags
- Supporting a multiplicity of adaptation and switching elements under the domain of a single controller.
- Providing an interface to the Adaptation Plane.
- Replicating data for point-to-multipoint connections providing a common switch control interface to one or more controllers.
- Partitioning and sharing resources within a physical switch.

2.3.2.1 Virtual Switch Function (VSF)

Any entity (e.g. switch or controller) may be partitioned into one or more subsets of resources. A partition of switch resources is called a VSF and is an arbitrary subset of switch resources that can be controlled as a unit. Switching resources are responsible for the switching of media streams from one logical port to another or to a functional entity. The VSF is also responsible for conveying state and availability information of its resources to the Virtual Switch Control Function (VSCF).

2.3.3 Description of Functions spanning the Switching and Adaptation Planes

2.3.3.1 Partitioning Function (PF)

Management creates a VSF using the sm reference point by specifying the switch resources that are to make up the partition. These resources include LPFs, physical port resources such as bandwidth, buffer space and physical switch resources such as forwarding table space.

The PF maintains partition integrity between partitions of a partitioned entity. Integrity is maintained in terms of the actual partitioned resources as well as in terms of the flow of control between a Controller and its controlled partition. The partitioned entity performs any necessary re-mapping of information in the Virtual Switch domain to references in the partitioned physical switch domain. This re-mapping between virtual and physical domains allows controllers to stay unaware of partitioning.

2.3.4 Control Plane Description and Functions

The Control Plane is responsible for the routing of traffic between Switching Plane, Adaptation Plane and Applications Plane within the switching system. The Control Plane allocates Switching Plane and Adaptation Plane resources. Specific functions of the Control Plane include:

- Routing & rerouting of traffic between switching complexes within an MSS as well as connections between MSSs.
- Commands establishment, modification and release of connections or flows, as well as, controlling the label mappings (e.g. VPI/VCI) between port interfaces.
- Assign traffic and QoS parameters for each connection or flow and performing admission control to assure that these parameters are met.
- Controlling the Adaptation Plane functions.
- Terminating and originating signaling from Trunk, NNI and UNI ports in conjunction with the Adaptation Plane.
- Providing call level statistics, Call Detail Records and alarms.
- The Control Plane should be modular and may include several, independent controllers. For example, it may include separate controllers for Voice/SS7, ATM/SVC, and even IP/MPLS services as shown in Figure 1.
- Receiving signaling information from each port and passing the information to other entities in the Control Plane.
- Negotiating connection and adaptation parameters, such as bit rate and codec type, with the peer Adaptation Plane Element at the far-end MSS. The Adaptation Plane provides control and reporting functions to the Control and Management Planes appropriate for these negotiation protocols.

2.3.4.1 Network Edge Control Function (NECF)

The NECF requests the creation, modification, and termination of LPF instances. The NECF is responsible for sending and receiving control information to and from a LPF regarding the media streams and other services (e.g., encryption) on those streams that it supports. This function tracks resource utilization and allocates resources (e.g., echo cancellers, tone detectors, etc.) to the logical ports. The NECF may allocate resources and apply services based on policy.

2.3.4.2 Virtual Switch Control Function (VSCF)

The VSCF controls and monitors the VSF and LPFs within a Partition. The VSCF provides the required cross-connect information, including traffic and QoS information, across the VSF from one LPF instance to one or more LPF instances using the VSC reference point. It receives information about the switching function and propagates this information to other functions that may change state as a result (i.e., BCF). The VSCF communicates the required service category and traffic parameter requirements to the LPF in order to provide QoS and SLA's using the sp reference point. Note that any instance of an LPF is controlled by either a VSCF or an NECF.

2.3.4.3 Bearer Control Function (BCF)

The BCF is a functional block containing the logic for establishing, modifying and releasing end-to-end bearers between end point(s) (i.e., LPFs) of a bearer connection. A given MSS could have none, one or any number of BCFs. In an MSS, the BCF interacts with the appropriate instance of the NSICF and receives the information required to setup a bearer connection. The BCF may perform one or more of the following functions:

- Manage and maintain the state of links under its control.
- Establish, manage and maintain the state of the required bearer path(s) for a specific Network Service Instance Function (NSICF) request and communicates this state to the NSICF.
- Signaling to peer entities (e.g., PNNI, MPLS).

If Topology information is required across the ic reference point:

- Obtain and maintain network topology information as related to peering and hierarchy.
- Manage and maintain the reachability state of end-to-end network paths.
- Manage and maintain the availability of network capacity and bandwidth.
- Provide updates to the NSICF about route availability in order to keep route updates accurate based on current availability.

If local switch control is performed by going through the BCF:

- Establish cross-connect/switching via the VSCF.

2.3.4.4 Network Service Instance Control Function (NSICF)

The NSICF contains the logic and information to establish, maintain, modify, and release a network service instance. Some examples of network service instances include a context, circuit switched calls (e.g., PSTN connection) and a flow (e.g., MPLS). The NSICF uses the NECF and the BCF to establish, maintain, and release the bearer(s) of the associated network service instance. The NSICF exchanges control and signaling information with other NSICFs directly or via a Signaling Gateway Function (SGF). The NSICF performs one or more of the following functions:

- Applies services/applications, screening, and policy either directly or indirectly via the Service Feature Gateway Function (SFGF) which provides additional network-based services.
- Determines or obtains the address and routing options for reaching the destination end point(s) and may select the route to be used.
- Identifies the control signaling, bearer signaling, and address requirements of a networks service instance and determines the network interworking requirements if required.
- Terminates and originates signaling (ix or ia flows) or provides the signaling interworking in order to map originating signaling to terminating signaling (ic to ia flows).
- Maintains information on the availability of path(s) to reach endpoint(s) based on routing information exchanged as well as from updates from the bearer control function.
- Requests the use of adaptation resources that are required in order to deliver the service (e.g., echo cancellers, tone generators, tone receivers etc.).
- Maintains service instance state information and provides information that is used in billing.
- Negotiate service instance characteristics with its peer.
- Establishes a cross-connect/switching via the VSCF.

2.3.4.5 Signaling Gateway Function (SGF)

The SGF is the functional block that processes signaling, entering and exiting a MSS (It maps, relays or tunnels the signaling information. The SGF may also screen or terminate the associated signaling. The action taken by the SGF can be different depending upon whether it performs a transport function or a control signaling function. After processing incoming signaling data, the SGF will deliver control signaling information to the appropriate instance of the NSICF via the appropriate transport mechanism. In general, the SGF maintains only enough information about the call state to manage the protocol interfaces.

2.3.5 Application Plane Description

The applications plane will include a wide variety of services at many "levels". Some of these services will implement their own service control logic and will be accessed directly in the applications plane, others may be triggered from the Control Plane as is the case in traditional voice. Examples of these services include the following:

- Information and Content Services
- Virtual Private Networks (VPNs) for voice and data
- Voice Services
- Video on Demand
- Group Based Multimedia Services (N-way multimedia calls, Whiteboard Applications...)
- Electronic Commerce and Call Centers
- Multiplayer real-time network gaming

2.3.5.1 Service Feature Gateway Function (SFGF)

The SFGF is a functional block allowing access to intelligent network services and other network provided applications. It also allows directly signaled services in the Application Plane to access the Control Plane functionality.

2.3.6 Management Plane Description and Functions

The Management Plane includes management functions, MIBs and interfaces within an MSS. Typical functions of the Management Plane include:

- Fault management
- Configuration management
- Accounting management
- Performance management
- Security management

The MSF Management Plane complements existing standards with functions, MIBs and interfaces that are required by the MSF Architecture. These new requirements, in part, stem from the fact that the MSF reference architecture defines a Virtual Switch Function (VSF) responsible for partitioning of switching resources into Virtual Switches (VS). This allows VSs to be created on some set of switches in the network to form a virtual network. Each virtual network (the VSs that make up the network) can be controlled by an independent Control Plane that should not be aware that it is controlling virtual switches rather than physical ones. Similarly, each virtual network can be managed by a separate network manager that need not be aware of the fact that it is managing a virtual network and not a physical one. In this environment, management functions are required on two levels: the first is the management of the Switch Function and the VSF, and second is the management of individual VSs. The former is referred to as the Super-Ordinate Level of management, whilst the latter is referred to as the Sub-Ordinate Level.

2.3.6.1 Super-ordinate Management Function (SupMF)

Management functions are required on the super-ordinate level to:

- Allow the creation, modification, and deletion of VSs.
- Partition and virtualize the management information and functions presented to the sub-ordinate management function corresponding to each VS.
- Manage the physical hardware. This allows the manager to perform FCAPS functions against the switch hardware.

2.3.6.2 Sub-ordinate Management Function (SubMF)

On the sub-ordinate level, management is required per VS to allow a controller to perform FCAPS functions on the VS. The super-ordinate and sub-ordinate management function requirements lead to the need for two types of Switch Management MIBs and the two reference points that the MSF will standardize.

2.4 Interfaces and reference points

A multiservice network requires the interaction of multiple switching systems operating at several planes in order to deliver a complete set of user services.

This section describes reference points between functions across a boundary between planes in the MSF Architecture for a potential requirement to specify a protocol and an interface to implement the interaction between the respective functional blocks.

2.4.1 Inter-plane interactions

This section describes the reference points from Figure 2 that cross planar boundaries. These are sometimes referred to as vertical interfaces.

2.4.1.1 Adaptation Plane – Control Plane

The Adaptation Plane supports a range of service interfaces between Control Planes, including UNIs and NNIs for Voice, IP, Frame Relay, Circuit Emulation and ATM services. Each service has a distinct set of attributes and signaling requirements that must be supported by the Adaptation-Control Plane interface (np or sp reference points). These protocols enable both the relaying of service signaling information as well as control of the Adaptation Plane functions. In the first release, MEGACO/H.248 is the protocol for providing Voice and N-ISDN services between the Adaptation and Control Planes, while GSMPv3 is the protocol for providing frame relay, ATM, MPLS and circuit emulation services.

Edge Control Signaling reference point (np):

This signaling association provides the signaling necessary to request the creation, modification, status or termination of a designated logical port session instance. The signaling messages have the capability of adding and deleting media streams to the logical port session instance.

Switch Port Signaling reference point (sp):

Via information flowing across this reference point the virtual switch function conveys information to the logical port function that establishes a correlation between labels associated with external data-flows.

2.4.1.2 Switching Plane - Control Plane

The MSF Architecture supports multiple independent controllers controlling logical switch partitions of a physical switch. The VSF is responsible for insuring the integrity of a switch that has been partitioned into multiple virtual switches.

Virtual Switch Control Signaling reference point (vsc):

This signaling association provides for the creation, modification, status, or termination of a connection path between logical ports. A connection may be point-to-point, point-multipoint, multipoint-point, or broadcast. Point-point connections may be unidirectional or bi-directional.

2.4.1.3 Switching Plane – Adaptation Plane

The Adaptation and Switching Planes are coordinated by the Control Plane via collaboration of the various control functions (NSICF, NECF, BCF, VSCF) as depicted by the MSF functional architecture. No reference point is defined between the Switching and Adaptation Planes in this version of the MSF Architecture.

2.4.1.4 Control Plane – Application Plane

The MSF Architecture supports a MSS communicating with applications over the sa and sg reference points. These reference points also allow applications in the Applications Plane to access the Control Plane functionality. Communication between the Control and Applications Plane may use open software APIs or open standardized physical interfaces. The MSF has not chosen to address the standards associated with these reference points as part of Release 1, but they are candidates for being addressed in future releases.

Service Access Signaling reference point (sa):

This signaling association provides the transport of service events, requests and responses between the NSICF and the SFGF.

Service Access Gateway Signaling reference point (sg):

This signaling association provides the transport of service requests and responses between external customers or networks and the applications plane via the SGF and the SFGF.

2.4.1.5 Management Plane– Switching & Adaptation Plane

The MSF leverages several industry standards and agreements regarding management. What is specific for the MSF is the standardization of new MIBs required by the MSF Architecture and new MSF specific management interfaces. The only interface between the management and the Adaptation and Switching Planes is provided through MIBs that offer an object abstraction of the Adaptation Plane through proprietary agents. The MSF will use industry standard network management protocols to implement the sm and vsm reference points and will specify protocol independent MIBs for the VS MIB and Partition Management (Partitioning MIB).

Three reference points in the Management Plane are identified. In addition, management flows occur at the SCI interface as well:

Switch Management reference point (sm):

The sm reference point enables the management of the switch through the following MIBs. These MIBs are referred to as the Switch Management MIB:

- The Switch Partitioning MIB is used specifically for configuration of VSs. Configuring a partition entails the specification of the resources that it contains.
- The GSMPv3 MIB is used specifically for management of the SCI instances presented by a switch to a controller.

Other standardized MIBs such as MIB I, MIB II, AToM MIB are used for the exchange of aggregated FCAPS management information relating to the underlying switching function (physical switch).

An interface for the sm reference point is subject to MSF standardization.

Virtual Switch Management reference point (vsm):

The vsm reference point is presented once for each VS created using the Partitioning MIB. Each instance of the vsm (each VS MIB) presents, to a sub-ordinate management function, a subset of the Switch MIB, which contains FCAPS information for one VS.

An interface for the vsm reference point is subject to MSF standardization.

2.4.1.6 Management – Control Plane

The MSF Architecture is intended to allow for widest possible choice of technologies to be used in the Control Plane. The development of new controllers and their standardization is though beyond the scope of MSF in Release 1.

Virtual Switch Control Management reference point (vscm):

Each sub-ordinate management function manages its corresponding VSCF over the vscm. The management of controllers is specific to the type of controller.

2.4.2 Intra-plane interactions

This section describes the reference points from Figure 2 within a single plane. These are sometimes referred to as horizontal interfaces.

2.4.2.1 Control Plane

2.4.2.1.1 Control – Control Plane, between same functions

This section describes reference points within the Control Plane categorized by whether they exist between the same function or between different functions.

At least the following Control-Control Plane interfaces and protocols operate between switching systems, as defined by the following bodies:

- ATM Forum (e.g., UNI, PNNI, AINI)
- IETF (e.g., MPLS LDP, OSPF, BGP, RSVP, IS-IS, RIP)
- ITU-T (e.g., DSS1, DSS2, ISUP, B-ISUP, BIC, TUP)

Inter-NSICF Signaling reference point (ia):

This signaling association provides the necessary signaling to request the establishment, modification and release of service instances and to transfer service instance information between instances of the NSICF.

Inter-MSS Bearer Control Signaling reference point (ic):

This signaling association provides the necessary signaling to request the establishment, modification and release of consistent local bearer mappings (e.g., MPLS LDP) between instantiations of the BCF.

External control signaling (ix):

This signaling association provides the necessary signaling for interconnecting different networks and/or technologies.

2.4.2.1.2 Control Plane- between different functions

Bearer Control Signaling reference point (bc):

This signaling association provides the necessary signaling interaction between the NSICF and the BCF to request and indicate the establishment, modification or release of an end to end bearer between MSS edge nodes.

Signaling Transport Signaling reference point (st):

This signaling association provides the transport of incoming and outgoing call & bearer signaling between the SGF and NSICF.

Network Service Instance Control Function (NSICF) to Virtual Switch Control Function (VSCF) reference point (bs’):

This reference point provides a means for the NSICF to control the VSF (via the VSCF) for the purpose of making a nodal level cross connect. It is used only when a BCF is not used for setting up an end to end bearer.

Bearer Control Function (BCF) to Virtual Switch Control Function reference point (VSCF) (bs):

This reference point provides a means for the BCF to control the VSF (via the VSCF) for the purpose of making a nodal level cross connect.

Network Service Instance Control Function (NSICF) to Network Edge Control Function reference point (mb):

A candidate reference point to be defined in a future MSF release.

2.4.2.2 Switching – Switching Plane (between same functions)

MSF has so far not considered an interface between like-to-like Switching - Switching Planes, since it is assumed that communication between Switch Functions interact over the Adaptation Plane.

2.4.2.3 Adaptation - Adaptation Plane (between same functions)

The Adaptation-Adaptation Plane interfaces specify the link-by-link bearer protocol stacks used by the various services. The intra MSS interfaces standardized by the MSF shall not hinder the full set of bearer capabilities that a MSS is expected to support.

2.5 Operational aspects of partitioning

Partitioning of resources is an important concept in the MSS architecture to meet the objectives stated in section 1.4 of logical separation, integrated services, separate controllers, and common trunking. This section defines the terminology used in the remainder of the document to describe the types of partitioning required.

2.5.1 Deterministic and Statistical Partitioning of Virtual Switch partitions

The sharing of resources between Virtual Switches may be either deterministic or statistical.

The first application of partitioning is expected to provide multiple instances of services to separate groups of users. These user groups expect no interference from each others' activities. This implies that the principle of resource sharing between partitions should be deterministic. At the same time, each partition must be able to use the resources allocated to that Virtual Switch in the most efficient manner; this has the consequence that the control logic of a partition still has the ability to use statistical allocation principles, for the resources within its partition.

More efficient utilization may be achieved if Virtual Switches statistically share pooled resources among several, otherwise non-cooperating control logic instances. As maybe obvious, the concept of statistical resource sharing between partitions is more difficult to define stringently than a deterministic one. The challenge lies in the continued ability to maintain service contract integrity and fair allocation of resources. Statistical partitioning of switches is currently outside the scope of Release 1 of the MSF architecture.

2.5.2 Static and Dynamic configuration of Virtual Switch partitions

The MSF Architecture implements configuration of Virtual Switch partitions through a separate management interface. The configuration can be either static or dynamic. The term static configuration means that the Virtual Switch partitions are established prior to the switching system as a whole being brought in service. The static configuration can be changed first after the switching system as a whole is brought out of service. The dynamic configuration principle allows for changes without bringing the switching system as a whole out of service.

3 SYSTEM MODULARITY CONCEPTS

3.1 System modularity

The concept of functional components of an MSS and associated information flows was to allow the construction of modular systems. In general any module that exposes an open interface can be supported. As described previously one of the goals was to allow physical separation of control from switching and adaptation and separation of control and forwarding. This section describes how such modularity may be obtained.

3.1.1 Separation of complexes for switching, control and management

The architecture meets the objective of modularity by clearly defining groupings of related functions with well-defined interfaces and functional definitions. Figure 3 illustrates the principal MSS components covered by the MSF. At the bottom of the figure, a switching complex comprised of a switching fabric and ports supporting ATM, voice, and other services acts under the control of a processor complex comprised of one or more processors executing multiple controller processes.

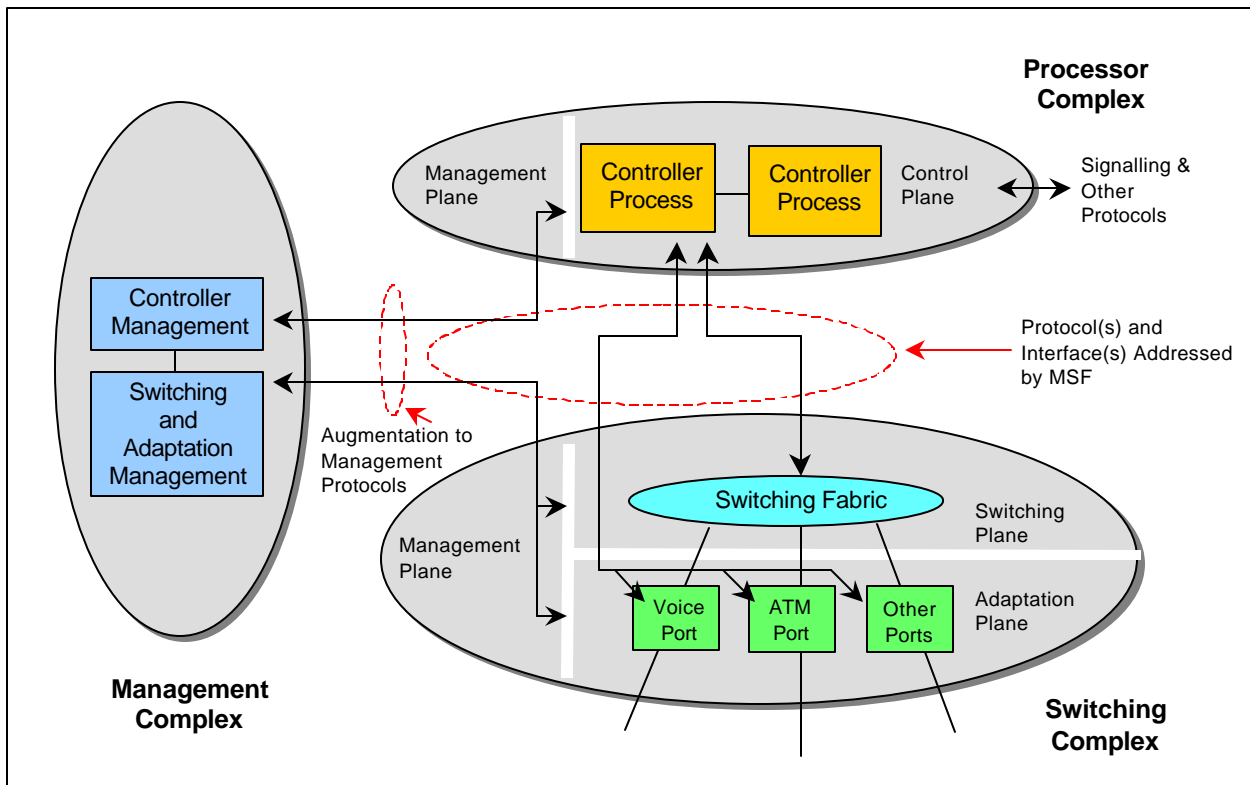

Figure 3 Multiservice Switching and Controller Complex Interface and Protocols

The switching complex contains ports implementing Adaptation Plane functions connected via a switching fabric. The switching complex connects to a cluster of one or more controller processes in a processor complex.

The processor complex includes computers running software that implement functions in the Control Plane. The protocol(s) and interface(s) between the controller processes in the processor complex and the processes in the switching complex are the principal topic addressed in the Multiservice Switching Forum in its initial Implementation Agreements.

3.1.2 MSS Network Model - Edge and Core Systems

Figure 3-2 The concept of edge MSSs and core MSS is valid when modeling how physical elements would be bundled together to create a network. The simplest context to define a system is the association of a single switching complex with a single controller complex. This definition implies that the four primary control functions (NSICF, NECF, BCF and VSCF) are located locally.

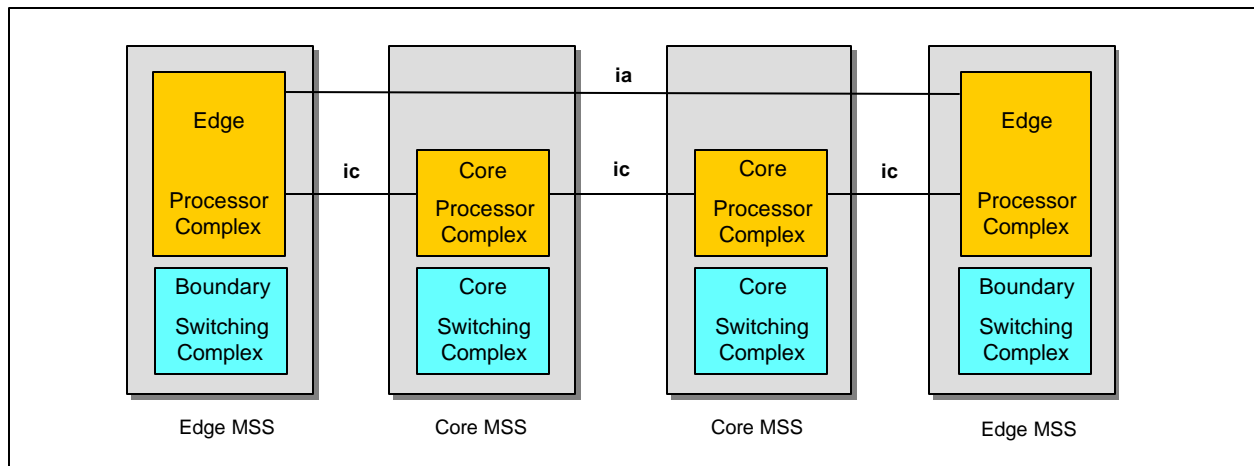

Figure 3-2 Edge and Core Systems

In an edge/core distribution, aggregation of services occurs at the edge of the network. This aggregated set of services is under the control of one controller complex that allows the edge devices to act as one virtual node. The core node also is supported by its own control complex and acts independently of the edge node. In this distribution, signaling between nodes occurs over the reference points ia and ic.

4 MAPPING OF MEGACOP/H.248 SYTEMS ONTO THE MSF ARCHITECTURE

This section shows how the MSF Architecture, while providing a modular architecture that is intended to accommodate future systems, can be used to realize configurations currently discussed in the industry. In MSF-ARCH-001.00, the MEGACO/H.248 protocol may run on top of 3 different set MSF defined reference points: np+bs, np+bc and np+bs'.

MEGACO/H.248 was first aimed at decomposing an H323 gateway into an Media Gateway Controller (MGC) and an Media Gateway (MG). Thus, for MSF implementers to use the MEGACO/H.248 protocol it is necessary to define a mapping between the MGC and MG and the different MSF functional block.

It has to be noted that reference points bs and bs' are mutually exclusive: while bs only exist in case 1, bs' only exist in case 2 or 3.

1st case : BCF in the MGC

In this case the BCF is in the MGC. The ic reference point supports the proxy signaling protocol as defined in the ATM-forum UNI4.0 IA. Np+ bs realize the MEGACO/H.248 protocol.

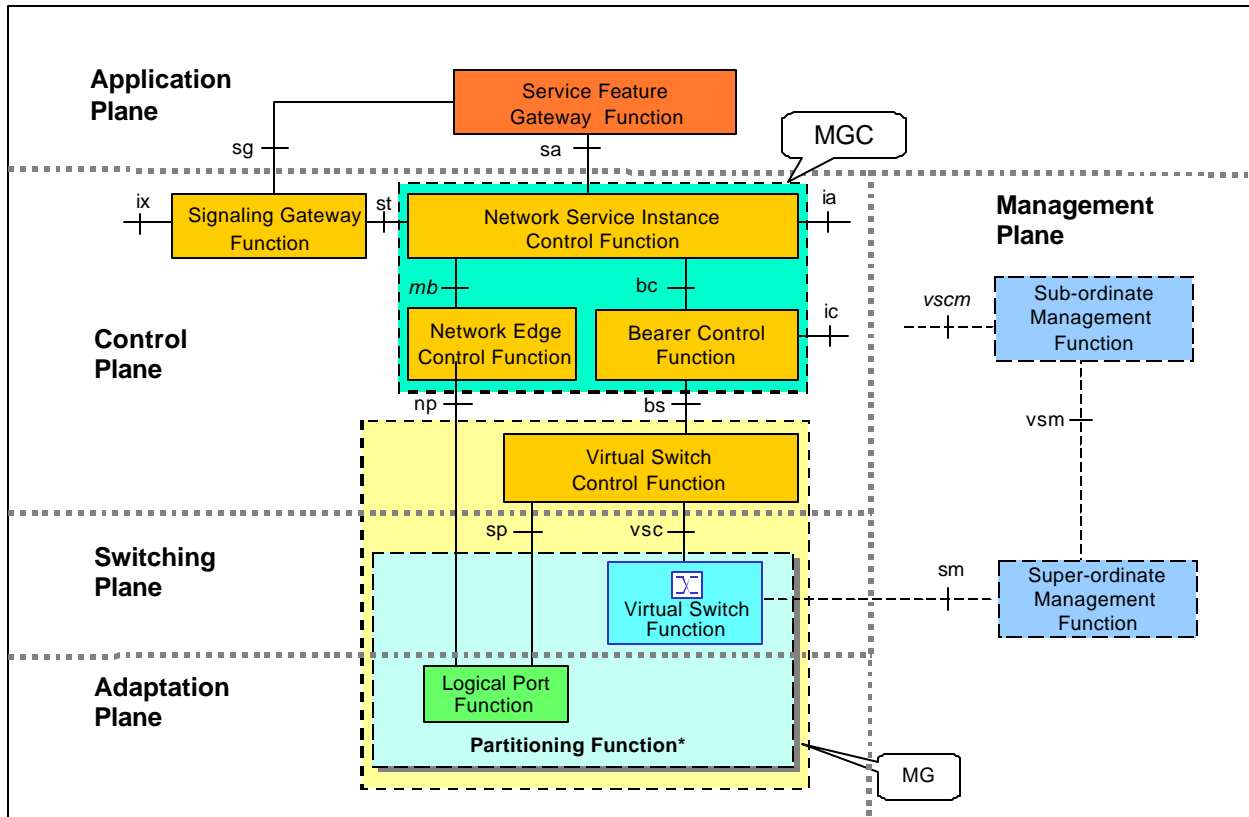

Fig 4: BCF in the MGC -> np + bs =H248/MEGACO, no bs'

2°) **BCF in the MG: np+bc = MEGACO/H.248**

In this case the BCF is in the MG. The BCF typically runs UNI 4.0, DSS2 or PNNI. In some cases it could also run CR-LDP. The conjunction of the np and bc reference points realize the MEGACO/H.248 protocol.

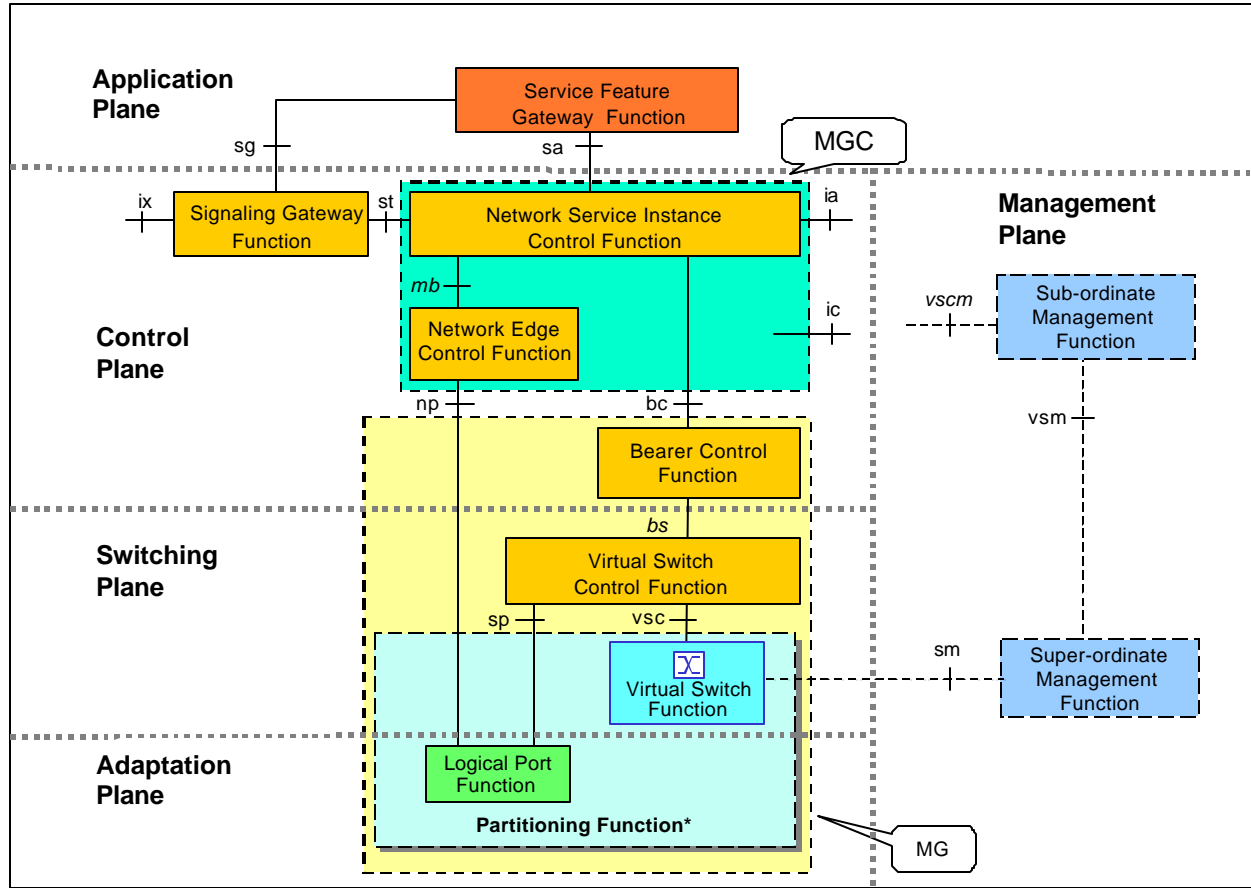

Fig 5: BCF in the MG -> np + bc = H248, no bs

3°) No BCF:

The BCF is not a mandatory functional block in the MSF-ARCH-001.00 therefore it can be omitted and this is specially the case for non connection oriented protocol such as IP without a MPLS architecture or without RSVP. Here np + bs' realize the MEGACO/H.248 protocol.

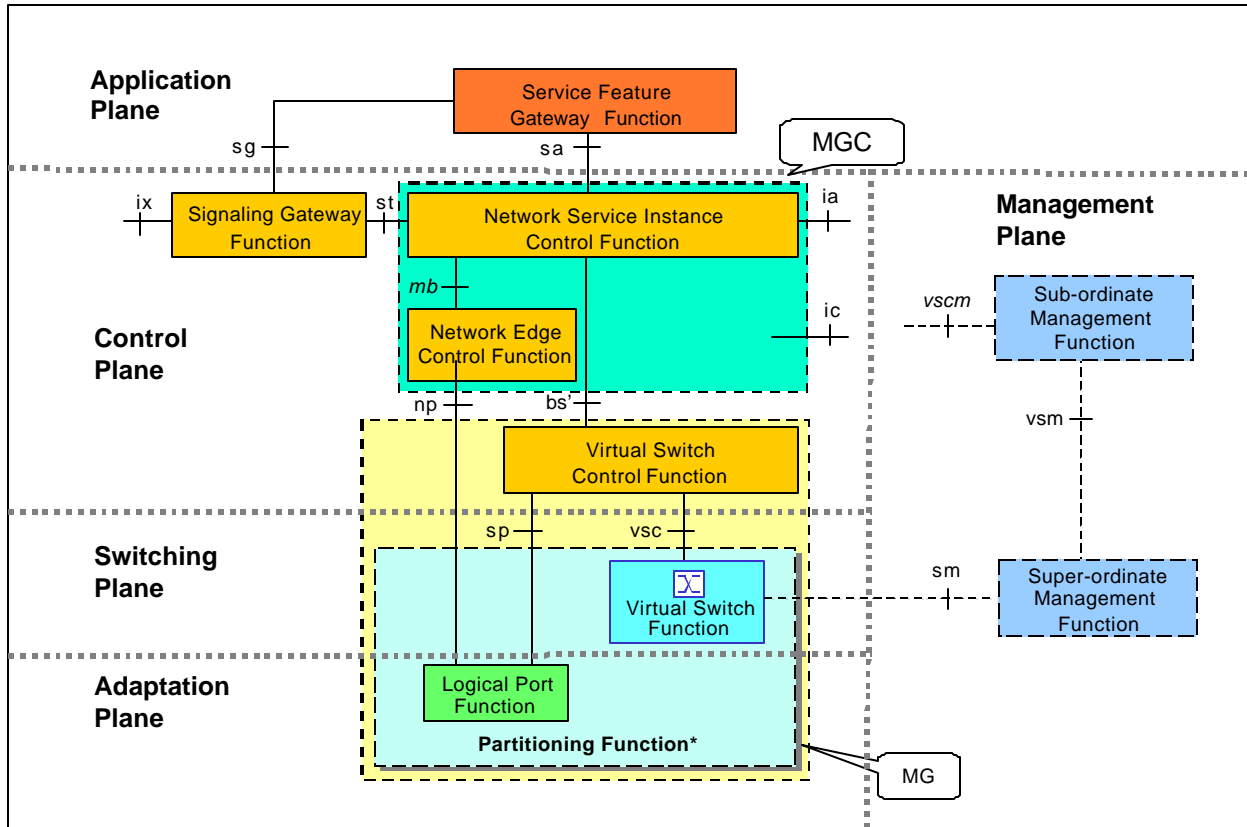

Fig 6: No BCF in the MSS->np + bs' = MEGACO/H.248