



**MSF Implementation Agreement for the
3GPP2 defined
Service Based Bearer Control - Tx interface**

MSF-IA-DIAMETER.013-FINAL

MultiService Forum Implementation Agreement

Contribution Number: msf2008.165.02

Document Filename: MSF-IA-DIAMETER.013-FINAL

Working Group: Protocol and Control

Title: Implementation Agreement for the 3GPP2 defined Service Based Bearer Control-
Tx Interface

Editor: Anil R. Gupta

argupta@alcatel-lucent.com

Working Group Chairperson: Chris Gallon, Fujitsu

Date: August 18, 2008

Abstract:

The MultiService Forum (MSF) is responsible for developing Implementation Agreements or Architectural Frameworks which can be used by developers and network operators to ensure interoperability between components from different vendors. MSF Implementation Agreements are formally ratified via a Straw Ballot and then a Principal Member Ballot.

Draft MSF Implementation Agreements or Architectural Framework may be published before formal ratification via Straw or Principal Member Ballot. In order for this to take place, the MSF Technical Committee must formally agree that a draft Implementation Agreement or Architectural Framework should be progressed through the balloting process. A Draft MSF Implementation Agreement or Architectural Framework is given a document number in the same manner as an Implementation Agreement.

Draft Implementation Agreements may be revised before or during the full balloting process. The revised document is allocated a new major or minor number and is published. The original Draft Implementation Agreement or Architectural Framework remains published until the Technical Committee votes to withdraw it.

After being ratified by a Principal Member Ballot, the Draft Implementation Agreement or Architectural Framework becomes final. Earlier Draft Implementation Agreements or Architectural Frameworks remain published until the Technical Committee votes to withdraw them.

The use of capitalization of the key words "MUST", "SHALL", "REQUIRED", "MUST NOT", "SHOULD NOT", "SHOULD", "RECOMMENDED", "NOT RECOMMENDED", "MAY" or "OPTIONAL" is as described in section V-B of the MSF Technical Committee Operating Procedures.

The goal of the MSF is to promote multi-vendor interoperability as part of a drive to accelerate the deployment of next generation networks. To this end the MSF looks to

adopt pragmatic solutions in order to maximize the chances for early deployment in real world networks.

To date the MSF has defined a number of detailed Implementation Agreements and detailed Test Plans for the signaling protocols between network components and is developing additional Implementation Agreements and Test Plans addressing some of the other technical issues such as QoS and Security to assist vendors and operators in deploying interoperable solutions.

The MSF welcomes feedback and comment and would encourage interested parties to get involved in this work program. Information about the MSF and membership options can be found on the MSF website <http://www.msforum.org/>

Note: Attention is called to the possibility that use or implementation of this MSF Implementation Agreement may require use of subject matter covered by intellectual property rights owned by parties who have not authorized such use. By publication of this Implementation Agreement, no position is taken by MSF as its Members with respect to the existence or validity of any intellectual property rights in connection therewith, nor does any warranty, express or implied, arise by reason of the publication by MSF of this Implementation Agreement. Moreover, the MSF shall not have any responsibility whatsoever for determining the existence of IPR for which a license may be required for the use or implementation of an MSF Implementation Agreement, or for conducting inquiries into the legal validity or scope of such IPR that is brought to its attention.

DISCLAIMER

The information in this publication is believed to be accurate as of its publication date. Such information is subject to change without notice and the MultiService Forum is not responsible for any errors or omissions. The MultiService Forum does not assume any responsibility to update or correct any information in this publication. Notwithstanding anything to the contrary, neither the MultiService Forum nor the publisher make any representation or warranty, expressed or implied, concerning the completeness, accuracy, or applicability of any information contained in this publication. No liability of any kind whether based on theories of tort, contract, strict liability or otherwise, shall be assumed or incurred by the MultiService Forum, its member companies, or the publisher as a result of reliance or use by any party upon any information contained in this publication. All liability for any implied or express warranty of merchantability or fitness for a particular purpose is hereby disclaimed.

The receipt or any use of this document or its contents does not in any way create by implication or otherwise:

Any express or implied license or right to or under any MultiService Forum member company's patent, copyright, trademark or trade secret rights which are or may be associated with the ideas, techniques, concepts or expressions contained herein; nor

Any warranty or representation that any MultiService Forum member companies will announce any product(s) and/or service(s) related thereto, or if such

announcements are made, that such announced product(s) and/or service(s) embody any or all of the ideas, technologies, or concepts contained herein; nor

Any commitment by a MultiService Forum company to purchase or otherwise procure any product(s) and/or service(s) that embody any or all of the ideas, technologies, or concepts contained herein; nor

Any form of relationship between any MultiService Forum member companies and the recipient or user of this document.

Implementation or use of specific MultiService Forum Implementation Agreements, Architectural Frameworks or recommendations and MultiService Forum specifications will be voluntary, and no company shall agree or be obliged to implement them by virtue of participation in the MultiService Forum.

For addition information contact:

MultiService Forum
48377 Fremont Blvd., Suite 117
Fremont, CA 94538 USA
Phone: +1 510 492-4050
Fax: +1 510 492-4001
info@msforum.org
<http://www.msforum.org>

I. The MultiService Forum

The MultiService Forum (MSF) is a global association of service providers, system suppliers and other organizations committed to developing and promoting open-architecture, multiservice communication systems. Founded in 1998, the MSF is an open-membership organization comprised of the world's leading telecommunications companies.

The MSF's activities include developing implementation agreements, promoting worldwide compatibility and interoperability, and encouraging input to appropriate national and international standards bodies.

As part of MSF's effort to drive and promote interoperability, the MSF has created a number of programs geared toward accelerating real world network deployments:

1. Global MSF Interoperability (GMI) events. GMI events provide a real-world setting for vendors to test their solutions and provide evidence that vendor products meet the interoperability standards set forth by MSF Implementation Agreements. Each MSF GMI event is built around a set of capabilities defined for a given release of the MSF Architecture.
2. Next Generation Network (NGN) Test Bed. The NGN test bed provides a facility to enable carriers and vendors to perform in-depth testing of a specific interface as defined in a given release of the MSF architecture.
3. Certification Programs. For more mature technologies the MSF can provide Certification of compliance to a given Implementation Agreement where MSF members believe that it is of value to the industry to do so.

II. An introduction to MSF documentation and GMI 2008

This document is part of the MSF Release 4 set of architectural, protocol and test documentation.

The MSF Release 4 Architecture is a physical implementation of the functional architectures that have been proposed by the key Standards Development Organizations. As such the MSF Release 4 Architecture represents the current state of the industry and it identifies current open interfaces between physically separate network elements.

MSF Implementation Agreements define the protocols to be used over specific open interfaces. Where possible MSF Implementation Agreements are based on industry standard protocols augmented with additional information so as to ensure interoperability between communicating network elements. This level of interoperability is achieved by closing any gaps and tightening any optional capabilities in those industry standards to remove the danger of mutually incompatible selections by vendors. An MSF Implementation Agreement is targeted at a given release of the MSF architecture but can

be used in any circumstance where an operator wishes to deploy the open interface and its functionality within their own network.

The MSF Release 4 architecture and its associated implementation agreements are used as the basis for GMI 2008. GMI 2008 is a global test event executed to demonstrate multi-vendor, multi-service interoperability based around IMS and includes IPTV and web based services.

As part of GMI 2008 a number of detailed test scenarios have been developed and a number of test plans defined. Test plans contain the set of test cases required to demonstrate a given MSF Release 4 capability and serve to exercise and validate the set of Implementation Agreements required to realize the capability.

Following the completion of GMI 2008 the MSF Release 4 architecture and individual implementation agreements will be updated if the testing identifies any deficiencies in the documents.

For more information about the scope of GMI2008 please go to <http://www.msforum.org>

III. Impact on previously published MSF documents

This is a new specification for MSF Release 4 and GMI2008.

Table of Contents

1. Introduction.....	8
1.1. Scope	8
1.2. References	8
1.3. Definitions and Abbreviations.....	9
1.3.1. Definitions	9
1.3.2. Abbreviations	9
2. Context for use of the TC-8 Interface.....	10
2.1. Policy and Charging Rules Server.....	10
2.2. Proxy-Call Session Control.....	11
2.3. Relationship between P-CSC and the PCRS	11
3. Overview of the TC-8 interface	12
3.1. Message Flow.....	12
3.1.1. AA-R / AA-A	12
3.1.2. RAR / RAA	13
3.1.3. STR / STA	14
3.1.4. ASR / ASA	14
4. Profiling of X.S0013-013-0 V1.0 [2].....	16

Introduction

1.1. Scope

This document defines the interface TC-8 in the MSF Release 4 architecture [1]. It is between the PCRS and the P-CSC to support Service Based Bearer Control (SBBC) features when a 3GPP2 enabled access tile connects to the MSF Core network.

It supports interactions between the PCRS and the P-CSC to:

- authorize the establishment of a service data flow
- authorize the modification of a service data flow
- revoke the authorization of a service data flow
- enable and disable a service data flow
- receive indication from the PCRS that the bearer resources are no longer available
- exchange of information with the PDSN via the PCRS for charging correlation
- provide information to the PCRS to determine dynamic charging rules.

The TC-8 reference point can be intra-domain or inter-domain.

This document is a profile of the 3GPP interface [2] defined in the 3GPP2 Architecture as the Tx reference point.

1.2. References

- [1] MSF Release 4 Architecture Overview (MSFR4-ARCH-OVERVIEW-FINAL)
- [2] 3GPP2 defined "All-IP Core Network Multimedia Domain. Service Based Bearer Control – Tx Interface Stage -3", X.S0013-013-0 V1.0
- [3] IETF RFC 3588, "Diameter Base Protocol", September 2003"

1.3. Definitions and Abbreviations

1.3.1. Definitions

Transport Control Block	The part of the MSF overall architecture framework that generically represents the elements responsible to control the transport network, independent of its technology
Access Network Tile	A specification of the architecture for a specific access network technology or a grouping of similar access technologies.
MSF Core Architecture Block	The functionality contained in the Transport, Session and Common Blocks defines in the MSF Architecture [1]

1.3.2. Abbreviations

3GPP2	3 rd Generation Partnership Project 2
AAA	Authentication, Authorization and Accounting
AA-A	AA-Answer
AA-R	AA-Request
AF	Application Function
ASA	Abort Session Answer
ASR	Abort Session Request
AVP	Application Value Pair
CC-R	CC-Request
CRF	Charging Rules Function
DNS	Domain Naming Service
FQDN	Fully Qualifies Domain Name
IA	Implementation Agreement
LBRF	Local Based Routing Function
PCRS	Policy and Charging Rules Server
PCRF	Policy and Charging Rules Function
P-CSC	Proxy – Call State Controller
PDP	Policy Decision Point
PDSN	Packet Data Serving Node
PEP	Policy Enforcement Point
QoS	Quality of Service
RAA	Re-Auth Answer
RAN	Radio Access Network
RAR	Re-Auth Request
SCTP	Stream Control Transmission Protocol
SPR	Subscriber Policy Register
STA	Session Termination Answer
STR	Session Termination Request
TCP	Transmission Control Protocol

2. Context for use of the TC-8 Interface

The MSF Release 4 architecture [1] incorporates access networks into its architectural framework. The generic interface between the MSF PCRS and P-CSC for QoS requests is identified by TC-8.

Figure 1 shows the context of the TC-8 interface between the MSF architectural components.

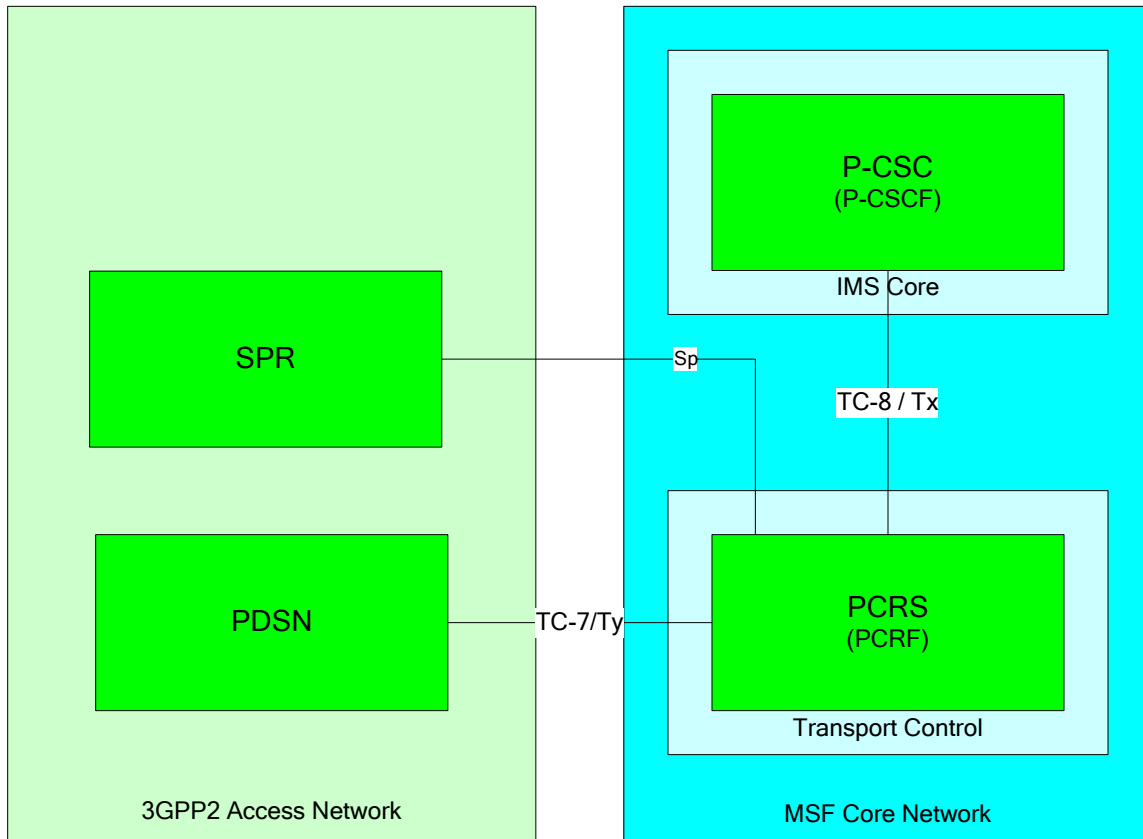

Figure 1: Context of the TC-8 Interface

Note: The Sp interface between the PCRS and the SPR is not defined in the MSF architecture.

2.1. Policy and Charging Rules Server

The PCRS is composed of the;

1. Policy Decision Point
2. Charging Rules Function

When acting as the Policy Decision Point (PDP) it is responsible for Service based QoS authorization and Local Resource Based Policy (LRBP) control. It makes decisions about bearer resource requests based on local network policy.

When acting as the Charging Rules Function (CRF) it is responsible to formulate the charging rules based on provisioned information, subscription information and input from the P-CSC and providing the same to the Traffic Plane function for enforcement. Based on operator determined

charging rules forwarded to it by the P-CSC, the PCRS is responsible to forward the same to the PDSN.

In the roaming case the PDSN is located in the visited network resulting in a home and visited PCRS being involved in the call. In this situation the V-PCRS may act as a proxy or redirect agent for communications between the PDSN and the H-PCRS.

The PCRS can optionally support the "Sp" interface towards a Subscriber Policy Register (SPR) located in the Access network for subscriber profile retrieval.

2.2. Proxy-Call Session Control

The P-CSC is an example of the Application Function (AF) that is responsible for requests to the PDSN for the purpose of controlling packet flows.

It is responsible to provide information to the PCRS to help determine dynamic charging rules for specifically identified service data flow which can include an application identifier, media component descriptors, charging identifier etc...

2.3. Relationship between P-CSC and the PCRS

There can be multiple instances of the P-CSC and PCRS within a single 3GPP2 enabled IMS network. In this case the following rules / restrictions apply

- The P-CSC can only interact with a PDSN via a PCRS. The PCRS acts on certain events using information provided by the P-CSC
- A P-CSC may interact with a number of PCRS's
- One PCRS shall be able to serve more than one P-CSC
- The P-CSC and the PCRS may exist within the same operator network or in separate networks
- The P-CSC and PCRS shall have a trust relationship
- The P-CSC and the H-PCRS may interact via a proxy or a re-direct agent

3. Overview of the TC-8 interface

The P-CSC communicates with the PCRS over the TC-8 which is based on the 3GPP2 defined Tx interface. This interface uses the Diameter protocol and uses the Diameter commands defined in RFC 3588 [3] for connection establishment and management.

This reference point can be inter-domain or intra-domain

The TC-8 interface identifies any P-CSC restrictions to be applied to the identified packet flow and supports the capabilities defined in Section 1 above.

The TC-8 interface supports the following Diameter commands between the P-CSC and PCRS;

1. AA-Request / AA-Answer
2. Re-Auth-Request / Re-Auth-Answer
3. Session-Termination-Request / Session-Termination-Answer
4. Abort-Session-Request / Abort-Session-Answer

Other commands SHOULD NOT be sent on the TC-8 interface and any responses that relate to these commands SHOULD be ignored by entities processing the TC-8 interface.

Of the information types defined by [2] this IA only makes request for bearer usage authorization and revocation. Requests are referenced by the IP Address of the end user as used in the access network.

3.1. Message Flow

The following sections explain how the diameter commands are used on the TC-8 interface.

3.1.1. AA-R / AA-A

The P-CSC sends the AA-Request command to the PCRS to request the authorization for bearer usage for a new session request. The PCRS responds back with an AA-Answer command

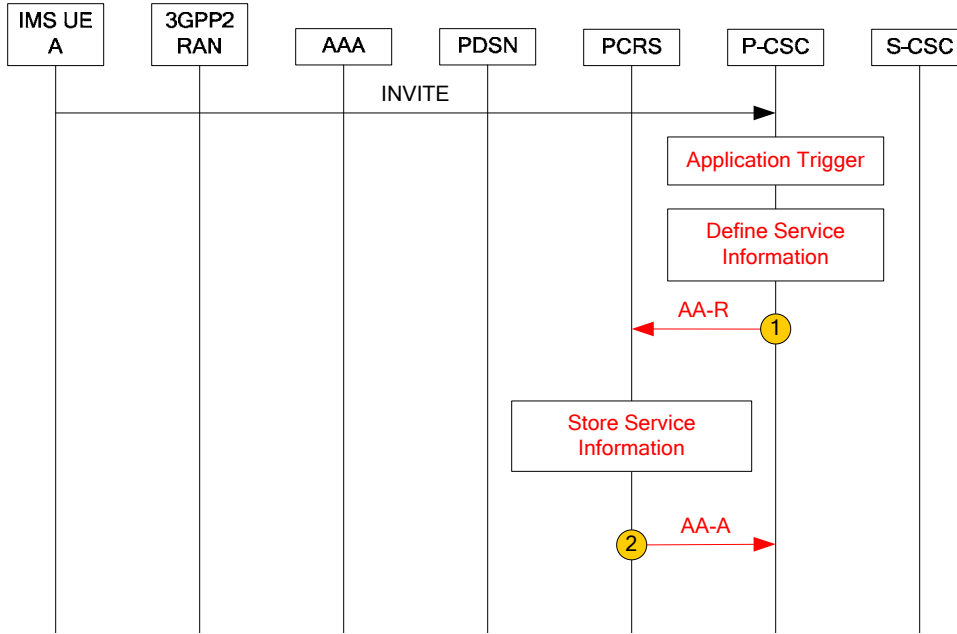

Figure 2: Example message flow that triggers AA-R/AA-A commands

3.1.2. RAR / RAA

The PCRS sends the Re-Auth-Request command to the P-CSC to indicate a specific action. The P-CSC responds back with a Re-Auth-Answer command.

It should be noted that under certain circumstances the P-CSC can send an AA-R command to the PCRS to update the Service Information on receipt of the RAR command.

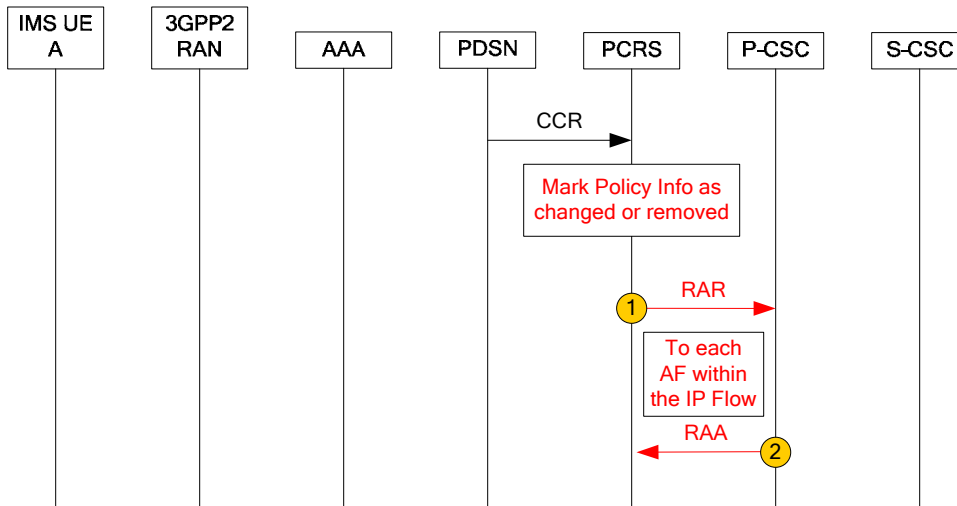

Figure 3: Example message flow that triggers RAR/RAA commands

3.1.3. STR / STA

The P-CSC sends the Session-Termination-Request command to the PCRS to inform the PCRS that an authorized session shall be terminated. The PCRS responds back with a Session-Termination-Answer command

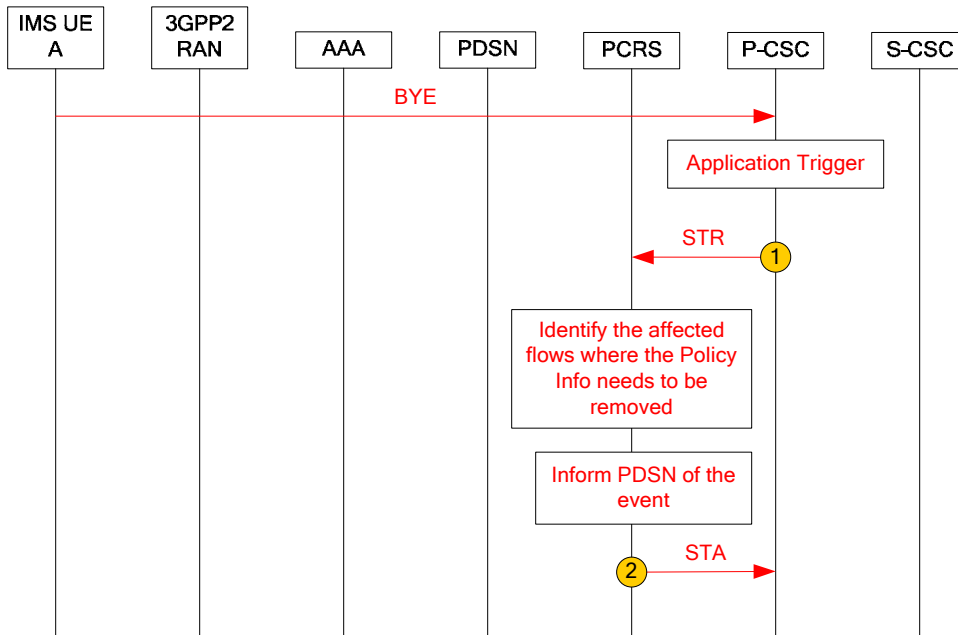

Figure 4: Example message flow that triggers STR/STA commands

3.1.4. ASR / ASA

The PCRS sends the Abort-Session-Request command to the P-CSC to inform it that all authorized bearer resources for a specific user have become unavailable. The P-CSC responds back with an Abort-Session-Answer command.

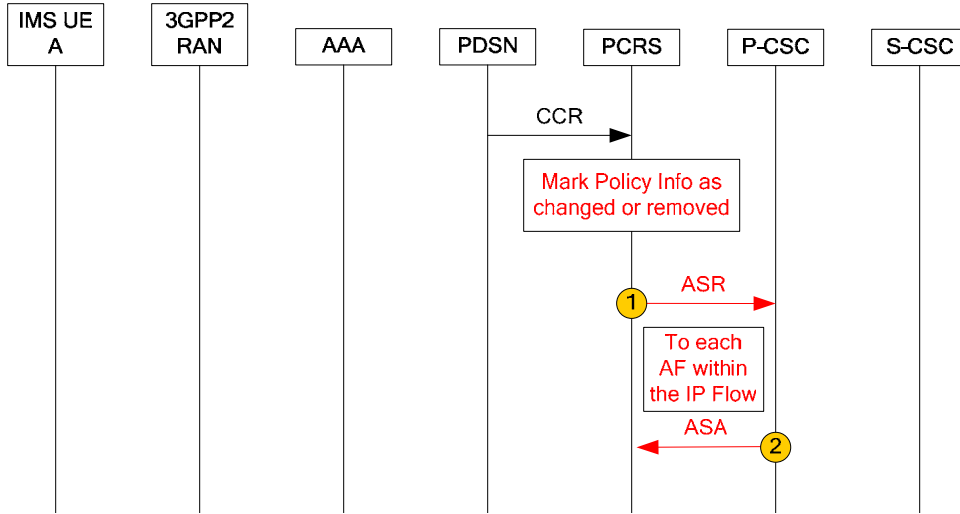

Figure 5: Example message flow that triggers AS-R/AS-A commands

4. Profiling of X.S0013-013-0 V1.0 [2]

The following is a profiling of the 3GPP2 standard X.S0013-013-0 [2], for the TC-8 interface showing the endorsements and changes to that document.

X.S0013-013-0 Section	Profiling Information
4. Procedures and Signaling Flows	
4.1 PCRF Procedures	
4.1.1 Initial Receipt of Service Information	Endorsed
4.1.2 AGW Initiated Requests	Endorsed
4.1.3 Gate Function	Endorsed
4.1.4 Session Modification	Endorsed
4.1.5 Loss of Flow Notification	Endorsed
4.1.6 AF Session Termination	Endorsed
4.1.7 Indication of IP Flow Release	Endorsed
4.1.8 Notification of Signaling Path Status	Endorsed
4.2 AF Procedures	
4.2.1 Provision of Service Information at Session Establishment	Endorsed
4.2.2 Flow Establishment	Endorsed
4.2.3 Gate Function	Endorsed
4.2.4 Session Modification	Endorsed
4.2.5 Flow Release	Endorsed
4.2.6 Subscription of Notification of Signaling Path Status	Endorsed
4.2.7 Session Termination	Endorsed
4.3 IMS related P-CSCF procedures	
4.3.1 Provision of Service information by P-CSCF	Endorsed
4.3.2 Enabling of IP Flows at P-CSCF	Endorsed
4.4 AF Service Information association to IP-CAN flows	Endorsed
4.5 AF Session Establishment or Modification	Endorsed
4.6 Request of Policy Information	Endorsed
4.7 Change or Removal of Policy Information at AF initiated session release	Endorsed
4.8 Flow Release	Endorsed
5. Tx Protocol	
5.1 Protocol Support	Endorsed.
5.2 Securing Diameter messages	Endorsed
5.3 Tx messages	Endorsed
5.3.1 AA-Request (AAR) Command	Endorsed
5.3.2 AA-Answer (AAA) command	Endorsed
5.3.3 Re-Auth-Request (RAR) command	Endorsed
5.3.4 Re-Auth-Answer (RAA) command	Endorsed
5.3.5 Session-Termination-Request (STR) command	Endorsed
5.3.6 Session-Termination-Answer (STA) command	Endorsed
5.3.7 Abort-Session-Request (ASR) command	Endorsed
5.3.8 Abort-Session-Answer (ASA) command	Endorsed
5.4 Experimental Result / Experimental-Result-Code AVP values	Endorsed
5.4.1 Experimental-Result AVP Message format	Endorsed
5.4.2 Experimental-Result-Code AVP	Endorsed
5.5 Tx Interface specific AVP's	Endorsed
5.5.1 Abort-Cause AVP	Endorsed

X.S0013-013-0 Section	Profiling Information
5.5.2 Access-Network-Charging-Address AVP	Endorsed
5.5.3 Access-Network-Charging-Identifier AVP	Endorsed
5.5.4 Access-Network-Charging-Identifier-Value AVP	Endorsed
5.5.5. AF-Application-Identifier AVP	Endorsed
5.5.6 AF-Charging-Identifier AVP	Endorsed
5.5.7 Codec-Data AVP	Endorsed
5.5.8 Flow-Description AVP	Endorsed
5.5.9 Flow-Number AVP	Endorsed
5.5.10 Flows AVP	Endorsed
5.5.11 Flow Status AVP	Endorsed
5.5.12 Flow-Usage AVP	Endorsed
5.5.13 Specific-Action AVP	Endorsed
5.5.14 Max-Requested-Bandwidth-DL AVP	Endorsed
5.5.15 Max-Requested-Bnadwidth-UL AVP	Endorsed
5.5.16 Media-Component-Description AVP	Endorsed
5.5.17 Media-Component-Number AVP	Endorsed
5.5.18 Media-Sub-Component AVP	Endorsed
5.5.19 Media-Type AVP	Endorsed
5.5.20 RR-Bandwidth AVP	Endorsed
5.5.21 RS-Bandwidth AVP	Endorsed
5.5.22 SIP-Forking-Indication AVP	Endorsed
5.5.23 Access-Network-Physical-Access-ID AVP	Endorsed
5.5.24 Access-Network-Physical-Access-ID-Value AVP	Endorsed
5.5.25 Access-Network-Physical-Access-ID-Realm AVP	Endorsed
5.6 Tx Re-used AVP's	Endorsed
<u>6. Binding Information</u>	
6.1 Overview	Endorsed
6.2 Session Binding	Endorsed
6.3 PCC Rule Authorization	Endorsed
6.4 Bearer Binding	Endorsed
Annex A (normative)	
A.1 QoS parameter mapping	Endorsed
A.1.1 Overview of QoS parameter mapping	Endorsed
A.2 QoS parameter mapping in the core network	Endorsed
A.2.1 SDP parameters to service information mapping in AF	Endorsed
A.2.2 Tx Service information to Authorized IP QoS parameters mapping in PCRF	Endorsed
A.2.3 Authorized IP QoS parameters to Authorized access network QoS parameters mapping in AGW	Endorsed
A.2.4 Comparing against the Authorized access network QoS parameters in AGW	Endorsed
A.3 QoS parameter mapping in the UE	Endorsed
A.3.1 Framework for QoS mapping in the UE	Endorsed
A.3.2 SDP to access network QoS parameter mapping in UE	Endorsed
A.3.3 SDP parameters to Authorized access network QoS parameters mapping in UE	Endorsed
Annex B (normative)	
B.1 Format of a flow identifier	Endorsed
B.1 Example	Endorsed
B.2 Example	Endorsed
Annex C (normative) Support for SIP Forking	

X.S0013-013-0 Section	Profiling Information
C.1 Support for SIP forking	Endorsed
C.1.1 Authorization of resources for early media for forked responses	Endorsed
C.1.2 Updating the authorization information at the final answer	Endorsed

Bibliography

- [1] 3GPP2 defined "All-IP Core Network Multimedia Domain. Service Based Bearer Control – Stage -2", X.S0013-012-0 V1.0
- [2] 3GPP2 defined "All-IP Core Network Multimedia Domain. Service Based Bearer Control – Tx Interface Stage -3", X.S0013-013-0 V1.0

End of Document