



**Implementation Agreement for the 3GPP Mc  
interface – 3GPP Release 6**

**MSF-IA-MC.002-FINAL**

# MultiService Forum Implementation Agreement

**Contribution Number:** msf2007.058.02

**Document Filename:** MSF-IA-MC.002-FINAL

**Working Group:** Protocol and Control

**Title:** Implementation Agreement for the 3GPP Mc interface – 3GPP Release 6

**Editor:** David Hutton, Vodafone

Tel - +44 7920 271321

Fax - +44 1635 238777

e-mail – david.hutton@vodafone.com

**Working Group Chairperson:** Chris Gallon, Fujitsu

**Date:** 13 September 2007

**Abstract:** In Release 4 of 3GPP specifications, the Bearer Independent Core Network architecture and associated protocol definitions were introduced. Amongst the new interfaces identified was the Mc interface. Mc interface connects the MSC-Server (3GPP parlance for a Media Gateway Control Function) and the Media Gateway, and is based on H.248.1 [3] with some additional packages used from Q.1950 [5] and further packages defined in the 3GPP specification itself (3GPP TS 29.232 [2]). The previous version of the Implementation Agreement is based on 3GPP Release 5 TS 29.232. This contribution aligns the MSF Implementation Agreement to the 3GPP Release 6 TS 29.232 [2].

The MultiService Forum (MSF) is responsible for developing Implementation Agreements or Architectural Frameworks which can be used by developers and network operators to ensure interoperability between components from different vendors. MSF Implementation Agreements are formally ratified via a Straw Ballot and then a Principal Member Ballot.

Draft MSF Implementation Agreements or Architectural Framework may be published before formal ratification via Straw or Principal Member Ballot. In order for this to take place, the MSF Technical Committee must formally agree that a draft Implementation Agreement or Architectural Framework should be progressed through the balloting process. A Draft MSF Implementation Agreement or Architectural Framework is given a document number in the same manner as an Implementation Agreement.

Draft Implementation Agreements may be revised before or during the full balloting process. The revised document is allocated a new major or minor number and is published. The original Draft Implementation Agreement or Architectural Framework remains published until the Technical Committee votes to withdraw it.

After being ratified by a Principal Member Ballot, the Draft Implementation Agreement or Architectural Framework becomes final. Earlier Draft Implementation Agreements or Architectural Frameworks remain published until the Technical Committee votes to withdraw them.

The use of capitalization of the key words “MUST”, “SHALL”, “REQUIRED”, “MUST NOT”, “SHOULD NOT”, “SHOULD”, “RECOMMENDED”, “NOT RECOMMENDED”, “MAY” or “OPTIONAL” is as described in section V-B of the MSF Technical Committee Operating Procedures.

The goal of the MSF is to promote multi-vendor interoperability as part of a drive to accelerate the deployment of next generation networks. To this end the MSF looks to adopt pragmatic solutions in order to maximize the chances for early deployment in real world networks.

To date the MSF has defined a number of detailed Implementation Agreements and detailed Test Plans for the signaling protocols between network components and is developing additional Implementation Agreements and Test Plans addressing some of the other technical issues such as QoS and Security to assist vendors and operators in deploying interoperable solutions.

The MSF welcomes feedback and comment and would encourage interested parties to get involved in this work program. Information about the MSF and membership options can be found on the MSF website <http://www.msforum.org/>

Note: Attention is called to the possibility that use or implementation of this MSF Implementation Agreement may require use of subject matter covered by intellectual property rights owned by parties who have not authorized such use. By publication of this Implementation Agreement, no position is taken by MSF as its Members with respect to the existence or validity of any intellectual property rights in connection therewith, nor does any warranty, express or implied, arise by reason of the publication by MSF of this Implementation Agreement. Moreover, the MSF shall not have any responsibility whatsoever for determining the existence of IPR for which a license may be required for the use or implementation of an MSF Implementation Agreement, or for conducting inquiries into the legal validity or scope of such IPR that is brought to its attention.

#### **DISCLAIMER**

The information in this publication is believed to be accurate as of its publication date. Such information is subject to change without notice and the MultiService Forum is not responsible for any errors or omissions. The MultiService Forum does not assume any responsibility to update or correct any information in this publication. Notwithstanding anything to the contrary, neither the MultiService Forum nor the publisher make any representation or warranty, expressed or implied, concerning the completeness, accuracy, or applicability of any information contained in this publication. No liability of any kind whether based on theories of tort, contract, strict liability or otherwise, shall be assumed or incurred by the MultiService Forum, its member companies, or the publisher as a result of reliance or use by any party upon any information contained in this publication. All liability for any implied or express warranty of merchantability or fitness for a particular purpose is hereby disclaimed.

The receipt or any use of this document or its contents does not in any way create by implication or otherwise:

Any express or implied license or right to or under any MultiService Forum member company's patent, copyright, trademark or trade secret rights which are

or may be associated with the ideas, techniques, concepts or expressions contained herein; nor

Any warranty or representation that any MultiService Forum member companies will announce any product(s) and/or service(s) related thereto, or if such announcements are made, that such announced product(s) and/or service(s) embody any or all of the ideas, technologies, or concepts contained herein; nor

Any commitment by a MultiService Forum company to purchase or otherwise procure any product(s) and/or service(s) that embody any or all of the ideas, technologies, or concepts contained herein; nor

Any form of relationship between any MultiService Forum member companies and the recipient or user of this document.

Implementation or use of specific MultiService Forum Implementation Agreements, Architectural Frameworks or recommendations and MultiService Forum specifications will be voluntary, and no company shall agree or be obliged to implement them by virtue of participation in the MultiService Forum.

**For addition information contact:**

MultiService Forum  
48377 Fremont Blvd., Suite 117  
Fremont, CA 94538 USA  
Phone: +1 510 492-4050  
Fax: +1 510 492-4001  
[info@msforum.org](mailto:info@msforum.org)  
<http://www.msforum.org>

## I Introduction

This Implementation Agreement covers the interface between a (Gateway) MSC-Server ((G)MSC-S) and a Media Gateway (MGW) in the 3GPP Bearer Independent Core Network Architecture (BICN) as first defined in the 3GPP Release 4. Within the 3GPP BICN architectural description (3GPP TS 23.205 [1]), this interface is identified as the Mc interface.

Whilst the architecture depicts functional separation between the G-MSC Server and the MSC-Server, this functional split is some what academic. In most deployments, all MSC-Servers will also take the role of G-MSC Server as well, offering interconnect to other networks. As such, whilst the Mc interface between MSC-Server and MGW may differ in terms of the functional requirements it supports compared with between the GMSC Server and MGW, implementation of (G)MSC Servers will be such that all Mc interface functionality is supported in all instantiations of the interface.

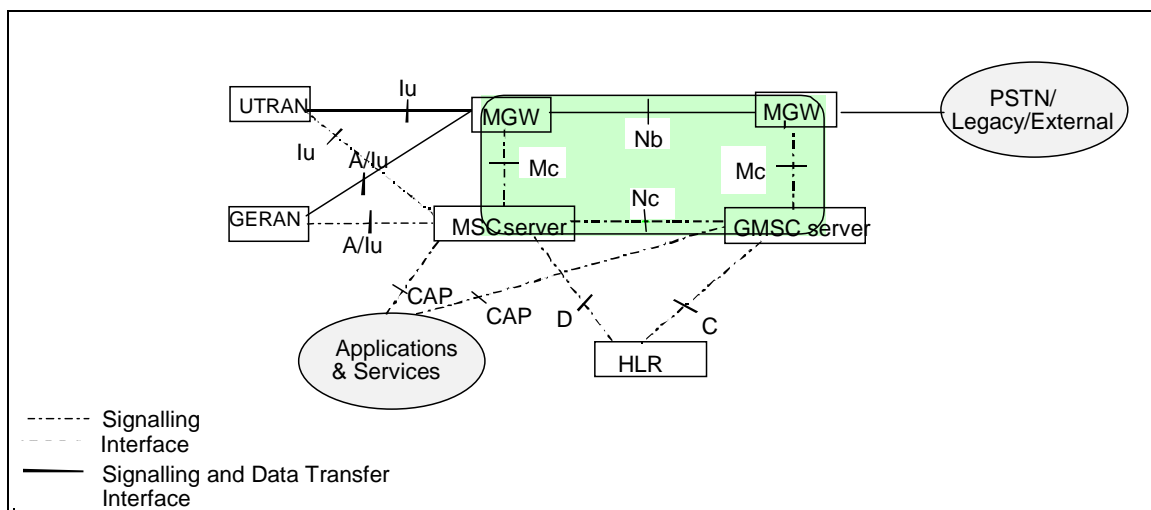

**Figure 1: BICN architecture (see 3GPP TS 23.205 [1])**

The Mc interface is defined in 3GPP TS 29.232 [2]. The document identifies that Mc interface is based on packages and procedures defined in H.248.1 [3], Q.1950 [5] and additional 3GPP specific functionality. However, until March 2005 little was included in 3GPP TS 29.232 [2] about the mandatory and/or optional implementation parts of the described packages and procedures, making cross-vendor interoperable implementations of the interface difficult and rare. In the new version of 3GPP TS 29.232 [2] produced in March 2005 considerable work was added to identify best implementation but due to the working practice of 3GPP, only changes that correct frequent and serious miss-operation can be included in earlier release specifications. Therefore, many useful changes could not be justified and so there is still scope for considerable divergence in implementation.

It is intended that this Implementation Agreement will further eliminate areas of ambiguity from implementations of the Mc interface. As such, this Implementation

Agreement will define specific implementation practices for devices wishing to implement Mc interface in an industry agreed way. This document is now put forward for Straw Ballot approval.

## **I.1 Problems with defining an Implementation Agreement of a 3GPP specification**

### **I.1.1 3GPP Release structure and Change Request mechanism**

3GPP work is completed in Releases, with each release containing the work completed under a number of Work Items to provide a complete set of specifications to allow for the implementation and deployment of functionality defined within that release. 3GPP also has a very strict policy regarding backwards compatibility, meaning that each Release is a super set of the previous Release.

During work on a specific release, requirements, architectures and protocols are defined until a point where the Release is considered closed. After that point specifications may still be updated using the Change Request process. Change Requests are submitted and assessed by relevant 3GPP Working Groups to determine whether they can be usefully incorporated into specifications. The deciding factor is whether the Change Request is addressing and solving a Frequent and Serious Miss-operation. Once the work on a Release is finished, it is only CR's that meet this criteria that can be agreed.

### **I.1.2 3GPP Mc specification across Releases**

3GPP first defined Mc interface in Release 4. The definition of the interface took place considerably in advance of product implementation and so was kept intentionally open. Since then, as implementations have been developed, some clearly obvious default options have been selected and the beginnings of a de facto standard implementation has become apparent. However, because 3GPP will only allow the correction of significant technical problems, and because backwards compatibility with all theoretically possible implementations must be maintained, it is not possible to document the de facto emerging standard in 3GPP in subsequent Releases.

## II Profile definition

Where implementation detail is not provided within this IA, 3GPP TS 29.232 [2] implementation specification shall take precedence over that in other specifications.

Except where otherwise indicated, each section that follows has the same number as the section of 3GPP TS 29.232 [2] which it modifies.

The following notation is used to identify the differing types of changes or modifications used compared to the specification in 3GPP TS 29.232 [2].

- <AP> - indicates a provision which adds precision, but no new normative content.
- <NEW> - indicates new normative content. <NEW> in a section header indicates that the section heading is new relative to 3GPP TS 29.232 [2].
- <CHG> - indicates changed normative content.

Note: The key words "MUST", "MUST NOT", "REQUIRED", "SHALL", "SHALL NOT", "SHOULD", "SHOULD NOT", "RECOMMENDED", "MAY", "OPTIONAL", "CONDITIONAL" and "IF" in this document are to be interpreted as described in the Technical Committee Operating Procedures.

### 1 Scope

No change.

### 2 References

The following references are shown specifically for use in this IA, but are redundant to 3GPP TS 29.232 [2]:

[1]	3GPP TS 23.205: Bearer-independent circuit-switched core network; Stage 2; Release 6
[2]	3GPP TS 29.232: Media Gateway Controller (MGC) - Media Gateway (MGW) interface; Stage 3; Release 6
[3]	ITU-T Recommendation H.248.1 version 2: Gateway Control Protocol
[4]	IETF RFC2960: Stream Control Transmission Protocol
[5]	ITU-T Recommendation Q.1950: Bearer Independent Call bearer Control Protocol
[7]	3GPP TS 29.414: Core network Nb data transport and transport signalling; Release 6
[8]	3GPP TS 29.205: Application of Q.1900 series to bearer-independent Circuit Switched (CS) core network architecture; Stage 3; Release 6
[9]	3GPP TS 29.202: "Signalling System No. 7 (SS7) signalling transport in core network; Stage 3; Release 6
[10]	IETF RFC3309: Stream Control Transmission Protocol (SCTP) Checksum Change
[11]	ITU-T Recommendation X.690 (2002)   ISO/IEC 8825-1:2002, Information Technology – ASN.1 encoding rules: Specification of Basic Encoding Rules (BER), Canonical Encoding

	Rules (CER) and Distinguished Encoding Rules (DER).
[12]	3GPP TS 29.232: Media Gateway Controller (MGC) - Media Gateway (MGW) interface; Stage 3; Release 7

<NEW> The following references are additional to those in 3GPP TS 29.232 [2]:

[6]	ITU-T Recommendation Q.1970: BICC IP Bearer Control Protocol
-----	--

### **3 Definitions, Symbols, and Abbreviations**

No change.

### **4 UMTS Capability Set**

<AP> The Profile and its version number SHALL be included in the ServiceChangeProfile parameter with the format “threegbicsn /2”.

#### **4.1 Profile Identification**

This Profile name SHALL be threegbicsn and its version shall be 2, as defined in 3GPP TS 29.232 [2].

#### **4.2 Profile Registration**

No change.

#### **4.3 <NEW>Encoding format**

<NEW> H.248.1 [3] commands sent on the Mc interface SHALL be encoded in binary ASN.1 format in accordance with ITU-T Recommendation H.248.1 [3] Annex A.

<NEW> The encoding rules which are applicable to the defined Abstract Syntaxes are the Basic Encoding Rules for Abstract Syntax Notation One, defined in ITU-T Recommendation X.690 [11]. Specifically in accordance with ITU-T Recommendation X.690 [11] section 7.3, alternative encodings based on the definite and indefinite form of length are permitted by the basic encoding rules as a sender's option. Receivers SHALL support both alternatives.

### **5 Naming Conventions**

No change.

#### **5.1 MGC/MGW Naming Conventions**

No change.

#### **5.2 Termination Names**

No change.

### 5.2.1 Termination Naming Convention

<AP> Termination ID 0xFFFFFFFF SHALL be used to indicate the ROOT termination.

<AP> Termination naming conventions on the Mc interface SHALL be encoded in binary ASN.1 format in accordance with ITU-T Recommendation H.248.1 [3] Annex A.

### 5.2.2 Termination Naming Convention For TDM Terminations

<AP> TDM termination naming conventions on the Mc interface SHALL be encoded in binary ASN.1 format in accordance with ITU-T Recommendation H.248.1 [3] Annex A.

## 6 Topology Descriptor

<AP> The Topology Descriptor SHALL be supported by the MGW and MGC for handover and lawful interception.

<AP> The Topology Descriptor MAY be supported by the MSC server for sending tones and playing announcements.

<AP> The Topology Descriptor SHALL be supported by the MGW for sending tones and playing announcements.

## 7 Transaction Timers

<AP> TransactionPending indication SHALL be used between MSC server and MGW as specified in ITU-T Recommendation H.248.1 [3].

## 8 Transport

<NEW> H.248.1 [3] commands sent on the Mc interface SHALL be encoded in binary ASN.1 format in accordance with ITU-T Recommendation H.248.1 [3] Annex A.

### 8.1 <NEW> IP Transport

<NEW> In an IP network, Mc interface protocol SHALL be transported over SCTP/IP. M3UA as specified for 3GPP in 3GPP TS 29.202 [9] SHALL NOT be included in the protocol stack if the network is all IP.

<NEW> Each H.248 control association SHALL be established over a single SCTP association.

<NEW> IPv4 transport SHALL be required in this version of the Interoperability Agreement. IPv6 is a potential future requirement.

<NEW> SCTP multi-homing functionality SHALL be supported as described in RFC2960 [4].

<NEW> Checksum calculation for SCTP as described in RFC 3309 [10] SHALL be supported.

<NEW> There shall be no limit placed on the maximum message size by the IP protocol implementation.

## 8.2 <NEW> ATM Transport

<AP> In an ATM network, Mc interface protocol SHALL be transported over MTP3b/SAAL\_NNI/ATM.

<NEW> The maximum message size SHALL be 4kBytes.

## 9 Multiple Virtual MG

<NEW> Each virtual MG SHALL be controlled over a separate SCTP association.

## 10 Formats and Codes

No change.

## 11 Mandatory Support of SDP and H.248.1 Annex C Information Elements

<AP> Following properties (defined in ITU-T Recommendation H.248.1 [3]) SHALL be supported for session description:

- ACodec
- TMR
- BIR
- NSAP
- USI

The support of this set of properties is defined in ITU-T Recommendation Q.1950 [5] as a mandatory requirement. No other H.248.1 Annex C properties SHALL be used for session description.

<AP> The NSAP and BIR properties are required only for AAL2 transport. The BIR property SHALL contain 4 octets. The NSAP property SHALL contain 20 octets.

<NEW> Properties supported on the Mc interface SHALL be encoded in binary ASN.1 format in accordance with ITU-T Recommendation H.248.1 [3] Annex A.

## 12 General On Packages and Transactions

<AP> The following commands SHALL be supported both by the MSC server and by the MGW:

ADD  
MODIFY  
MOVE  
SUBTRACT  
NOTIFY  
SERVICE CHANGE  
AUDIT VALUE

<NEW> The following command SHALL NOT be supported by the MSC server and by the MGW:

#### AUDIT CAPABILITY

<AP> The wildcarding of Termination names SHALL be supported.

<NEW> Changes of the service state of a Termination initiated by the MGC (e.g. by using ServiceChange command or Modify with TerminationState descriptor) SHALL NOT be permitted.

<NEW> The ServiceChangeAddress parameter SHALL NOT be used in this Profile.

<AP> Following Context attribute SHALL be supported:

- emergency indicator as specified in ITU-T Recommendation H.248.1 [3].

<AP> Replacement of descriptors SHALL be handled as described in ITU-T Recommendation H.248.1 [3].

<AP> Signal descriptor SHALL be used in this Profile.

<AP> TerminationState descriptor SHALL be used in this Profile.

<AP> Events Descriptor SHALL be used in this Profile.

<AP> Audit Descriptor SHALL be used in this Profile.

<AP> Error Descriptor SHALL be used in this Profile.

<AP> ServiceChange Descriptor SHALL be used in this Profile.

<NEW> Audit commands SHALL NOT be combined with commands that initiate Context manipulation.

<NEW> If the emergency indicator is set to true the MGW SHALL NOT reject or drop that H.248 request message from the MSC Server if the MGW is in an overload scenario.

<NEW> The BCP/BNCChar property SHALL be included in the LocalControl descriptor for all Iu and Nb terminations. It SHALL contain one of the following values: aal2 (2), or ip/rtp (4)..

### 13 <NEW> Bearers

<NEW> Different bearer types (ATM, IP) SHALL be supported in the same Context.

#### 13.1 Mandatory BICC Packages

No change.

#### 13.2 Optional BICC Packages

No change.

### 14 H.248 Standard Packages

<AP> Multiple procedures sent within a single command SHALL be supported.

#### **14.1 Call Independent H.248 Transactions**

No change.

#### **14.2 Call Related H.248 Transactions**

<NEW> IP Bearer Modification procedures as described in 14.2.27, 14.2.38, and 14.2.39.  
SHALL NOT be supported.

### **15 UMTS Packages**

No change.

#### **15.1 Mandatory UMTS Packages**

No change.

#### **15.2 Optional UMTS Packages**

No change.

### **Annexes A, B**

No change.

## **Annex C (Normative): Profile Description**

<AP> All of Annex C refers to 3GPP TS 29.232 Release 7 [12].

### **C.1 Profile Identification**

<CHG> The profile version number SHALL be version 2.

### **C.2 Summary**

No change.

### **C.3 Gateway Control Protocol Version**

No change.

### **C.4 Connection Model**

No change.

### **C.5 Context Attributes**

No change.

### **C.6 Terminations**

No change.

#### **C.6.1 Termination Names**

No change.

##### **C.6.1.1 General**

No change.

##### **C.6.1.2 ASN.1 Coding**

No change.

###### **C.6.1.2.1 General Structure**

No change.

###### **C.6.1.2.2 Termination naming convention for TDM terminations**

No change.

###### **C.6.1.3 ABNF Coding**

<CHG> ABNF Coding of TDM termination SHALL NOT be allowed on the Mc Interface. TDM terminations shall be ASN.1 coded.

#### **C.6.1.3.1 General Structure**

<CHG> ABNF Coding of TDM termination SHALL NOT be allowed on the Mc Interface. TDM terminations shall be ASN.1 coded.

#### **C.6.1.3.2 Termination naming convention for TDM terminations**

<CHG> ABNF Coding of TDM termination SHALL NOT be allowed on the Mc Interface. TDM terminations shall be ASN.1 coded.

#### **C.6.1.3.3 Termination naming convention for Ephemeral terminations**

<CHG> ABNF Coding of TDM termination SHALL NOT be allowed on the Mc Interface. TDM terminations shall be ASN.1 coded.

### **C.6.2 Multiplexed terminations**

No change.

## **C.7 Descriptors**

No change.

### **C.7.1 Stream Descriptor**

No change.

#### **C.7.1.1 LocalControl Descriptor**

No change.

#### **C.7.2 Events Descriptor**

No change.

#### **C.7.3 EventBuffer Descriptor**

No change.

#### **C.7.4 Signals Descriptor**

No change.

#### **C.7.5 DigitMap Descriptor**

No change.

#### **C.7.6 Statistics Descriptor**

No change.

#### **C.7.7 ObservedEvents Descriptor**

No change.

#### **C.7.8 Topology Descriptor**

<AP> The Topology Descriptor SHALL be supported by the MGW and MGC for handover and lawful interception.

<AP> The Topology Descriptor MAY be supported by the MSC server for sending tones and playing announcements.

<AP> The Topology Descriptor SHALL be supported by the MGW for sending tones and playing announcements.

### **C.7.9 Error Descriptor**

No Change.

## **C.8 Command API**

No change.

### **C.8.1 Add**

<AP> Text Encoding SHALL NOT be allowed as H.248.1 [3] commands sent on the Mc interface SHALL be encoded in binary ASN.1 format in accordance with ITU-T Recommendation H.248.1 [3] Annex A.

### **C.8.2 Modify**

<AP> Text Encoding SHALL NOT be allowed as H.248.1 [3] commands sent on the Mc interface SHALL be encoded in binary ASN.1 format in accordance with ITU-T Recommendation H.248.1 [3] Annex A.

### **C.8.3 Subtract**

No change.

### **C.8.4 Move**

<AP> Text Encoding SHALL NOT be allowed as H.248.1 [3] commands sent on the Mc interface SHALL be encoded in binary ASN.1 format in accordance with ITU-T Recommendation H.248.1 [3] Annex A.

### **C.8.5 AuditValue**

<CHG> The Hanging Termination Package ITU-T H.248.36 is not supported within 3GPP TS 29.232 Release 6 [2] and therefore auditing an individual termination MAY NOT be supported.

### **C.8.6 AuditCapabilities**

<AP> AuditCapabilities command SHALL NOT be supported by the MSC server and by the MGW.

### **C.8.7 Notify**

No change.

### **C.8.8 ServiceChange**

No change.

### **C.8.9 Manipulating and auditing context attributes**

No change.

## **C.9 Generic command syntax and encoding**

<AP> H.248.1 [3] commands sent on the Mc interface SHALL be encoded in binary ASN.1 format in accordance with ITU-T Recommendation H.248.1 [3] Annex A.

<NEW> The encoding rules which are applicable to the defined Abstract Syntaxes are the Basic Encoding Rules for Abstract Syntax Notation One, defined in ITU-T Recommendation X.690 [11]. Specifically in accordance with ITU-T Recommendation X.690 [11] section 7.3, alternative encodings based on the definite and indefinite form of length are permitted by the basic encoding rules as a sender's option. Receivers SHALL support both alternatives.

## **C.10 Transactions**

No change.

## **C.11 Messages**

No change.

## **C.12 Transport**

<AP> In an IP network, Mc interface protocol SHALL be transported over SCTP/IP. M3UA as specified for 3GPP in 3GPP TS 29.202 [9] SHALL NOT be included in the protocol stack if the network is all IP.

<NEW> Each H.248 control association SHALL be established over a single SCTP association.

<NEW> There shall be no limit placed on the maximum message size by the IP protocol implementation.

<AP> In an ATM network, Mc interface protocol SHALL be transported over MTP3b/SAAL\_NNI/ATM.

<NEW> The maximum message size SHALL be 4kBytes.

## **C.13 Security**

No change.

## **C.14 Packages**

<CHG> Optional package Hanging Termination Detection package ITU-T Recommendation H.248.36 MAY NOT be supported.

<CHG> Optional package ASCII Group call package SHALL NOT be supported.

<CHG> Optional package IP Domain connection package ITU-T Recommendation H.248.41 MAY NOT be supported.

### **C.14.1 Generic Package**

No change.

**C.14.2 Base Root Package**

No change.

**C.14.3 Tone Generator Package**

No change.

**C.14.4 Tone Detection Package**

No change.

**C.14.5 Basic DTMF Generator Package**

No change.

**C.14.6 Basic DTMF Detection Package**

No change.

**C.14.7 Continuity Package**

No change.

**C.14.8 TDM Circuit Package**

No change.

**C.14.9 Text Telephony Package**

No change.

**C.14.10 Call Discrimination Package**

No change.

**C.14.11 Announcement Package**

No change.

**C.14.12 Media Gateway Resource Congestion handling Package**

No change.

**C.14.13 Hanging Termination Package**

<CHG> Optional package Hanging Termination Detection package ITU-T Recommendation H.248.36 MAY NOT be supported.

**C.14.14 Bearer Characteristics Package**

No change.

**C.14.15 Generic Bearer Connection Package**

No change.

**C.14.16 Bearer Control Tunnelling Package**

No change.

**C.14.17 Basic Call Progress Tones Generator with Directionality**

No change.

**C.14.18 Expanded Call Progress Tones Generator Package**

No change.

**C.14.19 Basic Services Tones Generation Package**

No change.

**C.14.20 Expanded Services Tones Generation Package**

No change.

**C.14.21 Intrusion Tones Generation Package**

No change.

**C.14.22 Business Tones Generation Package**

No change.

**C.14.23 3GUP Package**

No change.

**C.14.234 Modification of Link Characteristics Bearer Capability**

No change.

**C.14.25 TFO package**

No change.

**C.14.26 Circuit Switched Data package**

No change.

**C.14.27 Enhanced Circuit Switched Data package**

No change.

**C.14.28 3G Expanded Call Progress Tones package**

No change.

**C.14.29 Cellular Text Telephone Modem Text Transport Package**

No change.

**C.14.30 IP Transport package**

No change.

**C.14.31 Flexible Tone Generator package**

No change.

### **C.14.32 Trace Package**

No change.

### **C.14.33 ASCII Group Call**

<CHG> Optional package ASCII Group call package SHALL NOT be supported.

### **C.14.34 IP domain connection**

<CHG> Optional package IP Domain connection package ITU-T Recommendation H.248.41 MAY NOT be supported.

## **C.15 Mandatory support of SDP and Annex C information elements**

<AP> Information Elements supported on the Mc interface SHALL be encoded in binary ASN.1 format in accordance with ITU-T Recommendation H.248.1 [3] Annex A.

## **C.16 Optional support of SDP and Annex C information elements**

No change.

## **Annex D**

No change.