



MSF Architecture for Non-3GPP Evolved Packet  
System (EPS) Access Tile

**MSF-LTE-ARCH-non3GPP-EPS-FINAL**

**MultiService Forum  
Architectural Framework**

Contribution Number: MSF2009.171.02  
File Name: MSF-LTE-ARCH-non3GPP-EPS-FINAL  
Document Filename: msf2009.171.02 Non-3GPP EPS Access Tile.doc  
Working Group: Architecture  
Title: **Architectural Framework for the  
Non-3GPP Evolved Packet System (EPS) Access Tile**

Editor: Shedman Tam  
Contact Information: [shedman.tam@alcatel-lucent.com](mailto:shedman.tam@alcatel-lucent.com)  
+1 613 784 4291

Working Group Chairperson: Stuart Walker

Last Uploaded: October, 2009

**Abstract:**

This document specifies the Architecture for the non-3GPP Evolved Packet System (EPS) Access Tile for use with the MSF Architectural Framework.

**DISCLAIMER**

The information in this publication is believed to be accurate as of its publication date. Such information is subject to change without notice and the MultiService Forum is not responsible for any errors or omissions. The MultiService Forum does not assume any responsibility to update or correct any information in this publication. Notwithstanding anything to the contrary, neither the MultiService Forum nor the publisher make any representation or warranty, expressed or implied, concerning the completeness, accuracy, or applicability of any information contained in this publication. No liability of any kind whether based on theories of tort, contract, strict liability or otherwise, shall be assumed or incurred by the MultiService Forum, its member companies, or the publisher as a result of reliance or use by any party upon any information contained in this publication. All liability for any implied or express warranty of merchantability or fitness for a particular purpose is hereby disclaimed. The receipt or any use of this document or its contents does not in any way create by implication or otherwise: Any express or implied license or right to or under any MultiService Forum member company's patent, copyright, trademark or trade secret rights which are or may be associated with the ideas, techniques, concepts or expressions contained herein; nor Any warranty or representation that any MultiService Forum member companies will announce any product(s) and/or service(s) related thereto, or if such announcements are made, that such announced product(s) and/or service(s) embody any or all of the ideas, technologies, or concepts contained herein; nor Any commitment by a MultiService Forum company to purchase or otherwise procure any product(s) and/or service(s) that embody any or all of the ideas, technologies, or concepts contained herein; nor Any form of relationship between any MultiService Forum member companies and the recipient or user of this document.

Implementation or use of specific MultiService Forum Implementation Agreements, Architectural Frameworks or recommendations and MultiService Forum specifications will be voluntary, and no company shall agree or be obliged to implement them by virtue of participation in the MultiService Forum.

**For addition information contact:**

MultiService Forum  
39355 California Street, Suite 307, Fremont, CA 94538  
Phone: (510) 608-5922 Fax: (510) 608-5917  
[info@msforum.org](mailto:info@msforum.org) [WWW.MSFORUM.ORG](http://WWW.MSFORUM.ORG)  
© MultiService Forum 2008

## Table of Contents

1. Introduction.....	4
1.1. Scope.....	4
1.2. Tile Prefix .....	4
1.3. References.....	4
1.4. Definitions and Abbreviations .....	7
1.4.1. Definitions.....	7
1.4.2. Abbreviations.....	7
2. Purpose.....	9
3. Overview of Relationship with the MSF Architectural Framework .....	9
4. Non-3GPP Access to Evolved Packet System (EPS) Access Tile Generic Architecture Overview.....	11
5. Trust Boundaries.....	12
6. Element Definitions .....	13
6.1. eAN/eRNC.....	13
6.2. AN-AAA.....	14
6.3. HSGW.....	14
6.4. 3GPP AAA .....	14
6.5. 3GPP2 AAA Proxy .....	15
6.6. ePDG .....	15
6.7. MME.....	16
6.8. SGW.....	16
6.9. PGW.....	17
6.10. HSS .....	17
6.11. UE.....	17
7. Principles of operation .....	17
7.1. E-UTRAN Attach .....	18
7.2. GERAN/UTRAN Attach .....	18
7.3. eHRPD Attach .....	18
7.4. Mobility Management and Handover within E-UTRAN .....	18
7.5. Mobility Management and Handover within eHRPD .....	18
7.6. Interworking between E-UTRAN and eHRPD.....	18
7.7. Non-Optimized Interworking.....	19
7.8. Optimized Interworking.....	19
7.9. Location Based Services .....	20
8. External Reference points.....	20
9. Internal Reference points .....	21

## Table of Figures

- Figure 1: Generic Relationship of the Access Domain within MSF Architectural Framework10  
Figure 2: Non-3GPP Access-Evolved Packet System Access Tile Architecture ..... 12

## 1. Introduction

### 1.1. Scope

This document defines the access tile architecture for non-3GPP Access to the Evolved Packet System (EPS) service. It includes the network attachment procedure for various access network configurations and the derivation of location information. It also includes bandwidth / QoS management of the media path.

### 1.2. Tile Prefix

The Tile Prefix for the non-3GPP Access to the Evolved Packet System access tile SHALL be “EPS2”

### 1.3. References

- [1] MSFR4-ARCH-OVERVIEW-FINAL, MSF Release 4 Architecture Overview
- [2] MSFR4-ARCH-CORE-FINAL, MSF Release 4 Core Architecture
- [3] MSFR4-ARCH-ACCESS-FINAL, MSF Access Architectural Framework
- [4] MSFR5-ARCH-EPS-FINAL, Architectural Framework for the 3GPP Evolved Packet System (EPS) Access Tile
- [5] 3GPP2 S.R0037: “IP Network Architecture Model for cdma2000 Spread Spectrum Systems”
- [6] 3GPP2 X.S0011: “cdma2000 Wireless IP Network Standard”
- [7] 3GPP2 A.S0017: “Interoperability Specification (IOS) for cdma2000 Access Network Interfaces – Part 7 (A10 and A11 Interfaces)”
- [8] 3GPP2 C.S0087: “E UTRAN - HRPD and CDMA2000 1x Connectivity and Interworking: Air Interface Aspects”
- [9] 3GPP2 X.S0057: “E UTRAN - eHRPD Connectivity and Interworking: Core Network Aspects”
- [10] 3GPP2 X.S0013: “All-IP Core Network Multimedia Domain”
- [11] 3GPP2 A.S0008: “High Rate Packet Data (HRPD) Radio Access Network Interfaces with Session Control in the Access Network (IOS)”

- [12] 3GPP2 A.S0009: "High Rate Packet Data (HRPD) Radio Access Network Interfaces with Session Control in the Packet Control Function (IOS)"
- [13] 3GPP2 A.S0022: "E-UTRAN - HRPD Connectivity and Interworking: Access Network Aspects (E-UTRAN – HRPD IOS)"
- [14] 3GPP2 C.S0063: "cdma2000 High Rate Packet Data Supplemental Services"
- [15] 3GPP2 C.S0067: "Generic Key Exchange Protocol for cdma2000 High Rate Packet Data Air Interface"
- [16] 3GPP TS 23.002: "Network Architecture (Release 8)"
- [17] 3GPP TS 23.401: "General Packet Radio Service (GPRS) enhancements for Evolved Universal Terrestrial Radio Access Network (E-UTRAN) access (Release 8)"
- [18] 3GPP TS 23.402: "Architecture enhancements for non-3GPP accesses (Release 8)"
- [19] 3GPP TS 36.300: "Evolved Universal Terrestrial Radio Access (E-UTRA) and Evolved Universal Terrestrial Radio Access Network (E-UTRAN); Overall description Stage 2"
- [20] 3GPP TS 23.003: "Numbering, addressing and identification"
- [21] 3GPP TS 29.002: "Mobile Application Part (MAP) specification (Release 8)"
- [22] 3GPP TS 23.203: "Policy and Charging Control Architecture"
- [23] 3GPP TS 29.212: "Policy and charging control over Gx reference point".
- [24] 3GPP TS 33.401: "3GPP System Architecture Evolution: Security Architecture".
- [25] 3GPP TS 33.402: "3GPP System Architecture Evolution: Security aspects of non-3GPP accesses"
- [26] 3GPP TS 29.275: "Proxy Mobile IPv6 (PMIPv6) based Mobility and Tunnelling protocols; Stage 3"
- [27] 3GPP TS 29.276: "Optimized Handover Procedures and Protocols between EUTRAN Access and cdma2000 HRPD Access"
- [28] IETF RFC 4306: "Internet Key Exchange Protocol Version 2".
- [29] IETF RFC 3748: "Extensible Authentication Protocol (EAP)".
- [30] IETF RFC 3344: "Mobility Support for IPv4".
- [31] IETF RFC 4285: "Authentication Protocol for Mobile IPv6".

- [32] IETF RFC 3775, "Mobility Support in IPv6".
- [33] IETF RFC 4282: "The Network Access Identifier".
- [34] IETF RFC 2131: "Dynamic Host Configuration Protocol".
- [35] IETF RFC 4039: "Rapid Commit Option for the Dynamic Host Configuration Protocol version 4 (DHCPv4)".
- [36] IETF RFC 3736: "Stateless Dynamic Host Configuration Protocol (DHCP) Service for IPv6"
- [37] IETF RFC1661: "The Point-to-Point Protocol (PPP)"
- [38] 3GPP TS 29.272: "Mobility Management Entity (MME) and Serving GPRS Support Node (SGSN) related interfaces based on Diameter protocol"
- [39] 3GPP TS 29.273: "3GPP EPS AAA interfaces"
- [40] 3GPP TS 29.274: "Evolved General Packet Radio Service (GPRS) Tunnelling Protocol for Control plane (GTPv2-C); Stage 3"
- [41] 3GPP TS 24.301: "Non-Access-Stratum (NAS) protocol for Evolved Packet System (EPS); Stage 3"
- [42] 3GPP TS 29.281: "General Packet Radio System (GPRS) Tunnelling Protocol User Plane (GTPv1-U)"
- [43] Void
- [44] 3GPP TS 29.213: "Policy and Charging Control signalling flows and QoS parameter mapping; (Release 8)"
- [45] MSFR4-ARCH-3GPP-FINAL, Architecture for 3GPP PS Access Tile

## 1.4. Definitions and Abbreviations

### 1.4.1. Definitions

The key words "MUST", "MUST NOT", "REQUIRED", "SHALL", "SHALL NOT", "SHOULD", "SHOULD NOT", "RECOMMENDED", "NOT RECOMMENDED", "MAY", "OPTIONAL", "CONDITIONAL" and "IF" in this document are to be interpreted as described in the MSF Technical Committee Operating Procedures.

Access Network Domain	The part of the overall MSF architecture framework that generically represents an access network, independent of its technology
Access Network Tile	A specification of the architecture for a specific access network technology or a grouping of similar access technologies.
MSF Core Architecture Domain	The functionality contained in the Transport, Session and Common Blocks defined in the MSF Architecture [2]
Customer Domain	The part of the overall MSF architecture framework that represents equipment residing with the customer or end user.

### 1.4.2. Abbreviations

3GPP	Third Generation Partnership Project
3GPP2	Third Generation Partnership Project 2
AAA	Authentication, Authorization, Accounting
AF	Application Function
AN	Access Network
BBER	Bearer Binding and Event Reporting
BTS	Base Transceiver System
DL	Down Link
DSCP	DiffServ Code Point
eAN	evolved AN
eHRPD	evolved HRPD
ePCF	evolved PCF
ePDG	evolved PDG
EPC	evolved Packet Core
FA	Foreign Agent
FFS	For Further Study
GTP	GPRS Tunnelling Protocol
GTP-C	GTP Control

GTP-U	GTP User
HRPD	High Rate Packet Data
HSGW	HRPD Serving Gateway
HSS	Home Subscriber Server
IMS	IP Multimedia System
IP	Internet Protocol
LMA	Local Mobility Anchor
MAG	Mobile Access Gateway
MAP	Mobile Application Part
MM	Mobility Management
MME	MM Entity
NGN	Next Generation Networks
OFCS	Offline Charging System
PCC	Policy and Charging Control
PCEF	Policy and Charging Enforcement Function
PCF	Packet Control Function
PCRF	Policy and Charging Rule Function
PCRS	Policy Charging Rules Server
P-CSC	Proxy-Call Session Control
PDG	Packet Data Gateway
PGW	Packet Gateway
PLMN	Public Land Mobile Network
PMIPv6	Proxy Mobile IP version 6
PPP	Point-to-Point Protocol
QoS	Quality of Service
QCI	QoS Class Identifier
RAN	Radio Access Network
RAT	Radio Access Technology
RNC	Radio Network Controller
SBBC	Session Based Bearer Control
SC	Session Control
S-CSC	Serving-Call Session Control
SGW	Serving Gateway
UE/AT or MS	User Equipment/Access Terminal or Mobile Subscriber

## 2. Purpose

This Access Network Tile is used to service a device that is IMS aware and attaches to an Evolved Packet System enabled network to offer traditional telephony / multimedia services within a converged NGN network. Note that the EPS2 access tile provides access for terminals connecting via the eHRPD radio access, and via other non-3GPP accesses through the ePDG. Access for 3GPP radio networks are described in MSF-ARCH-EPS-FINAL [4].

## 3. Overview of Relationship with the MSF Architectural Framework

The MSF Release 4 architecture [1] introduced an Access Network Domain into its architectural framework (see Figure 1). The Access Network Domain has a number of standard interfaces defined that are independent of the network access technology. This allows the architectural framework to define the interaction between the MSF core architecture domain and access network entities in order to support common capabilities such as extracting location information associated with access network attachment and managing access bandwidth allocation. As access technologies differ from one another, so do the mechanisms internal to that access network domain that support these interfaces. To accommodate this, a generic access domain is defined with the MSF architectural framework with common interfaces [3]. To facilitate adding different and multiple access networks to the overall architecture, each access network technology or group of similar technologies is defined in its own 'Access Network Tile' architecture that can be substituted for the generic access domain. Each Access Network Tile specifies how it operates internally and supports a sub-set of the common interfaces with the MSF Core Architecture Domain [2].

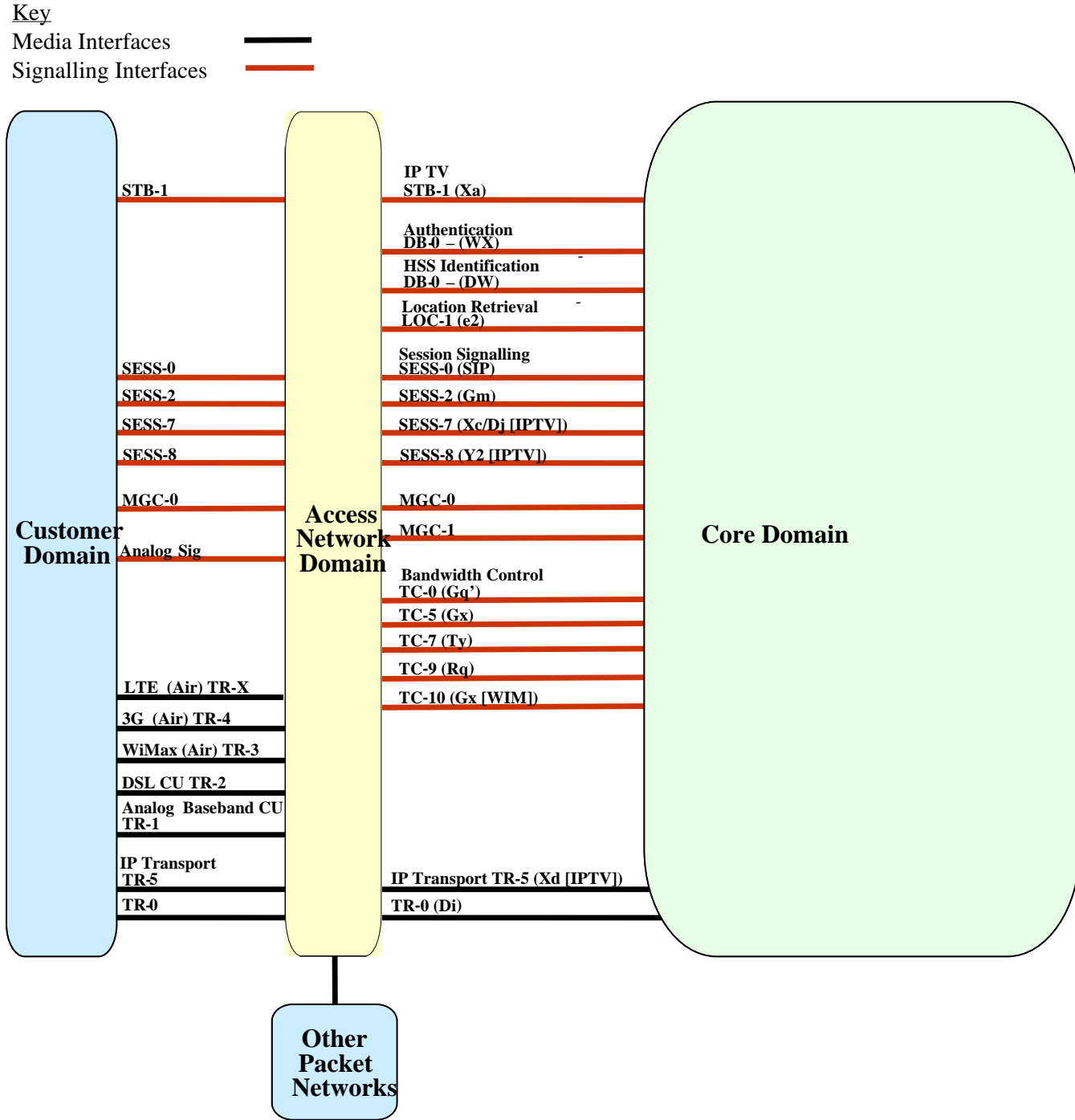

**Figure 1: Generic Relationship of the Access Domain within MSF Architectural Framework**

The common interfaces between the MSF Core Architecture Domain and the Access Block are for Bandwidth Control (TC-5) and IP transport (TR-0).

#### **4. Non-3GPP Access to Evolved Packet System (EPS) Access Tile Generic Architecture Overview**

The figure below is a representation of the network elements that form the basis of a 3GPP defined Evolved Packet System network for non-3GPP Access, capable of interworking with an IMS network and deliver IMS services to the end user. The architecture is based on the principles defined in 3GPP TS 23.002 [16], 3GPP TS 23.401 [17] and 3GPP TS 23.402 [18].

In the evolved High Rate Packet Data (eHRPD) access, Proxy Mobile IPv6 (PMIPv6) is used within the network to support mobility management. The BBER function in the HSGW performs bearer binding and event reporting as defined in 3GPP TS 23.203 [22] and communicates with the PCRF over the Gxa reference point. On the other hand, consistent with the architecture specified in msf2009.013 [4], the EPS is assumed to be GTP based and the Policy and Charging Control (PCC) function is implemented between the PGW and the PCRF over the Gx reference point. The Gxc reference point between the SGW and the PCRF is only used for PMIP based S5 and S8, and may be introduced into the EPS and EPS2 access tile architecture, in the future as required.

NOTE: In Figure 2 certain nodes may be physically collocated with each other. E.g. SGW collocated with PGW (in non-roaming scenarios), P-CSC in the access network collocated with S-SBG-NE in the MSF IMS Core Network. The HSS is collocated with HSS in MSF IMS Core Network.

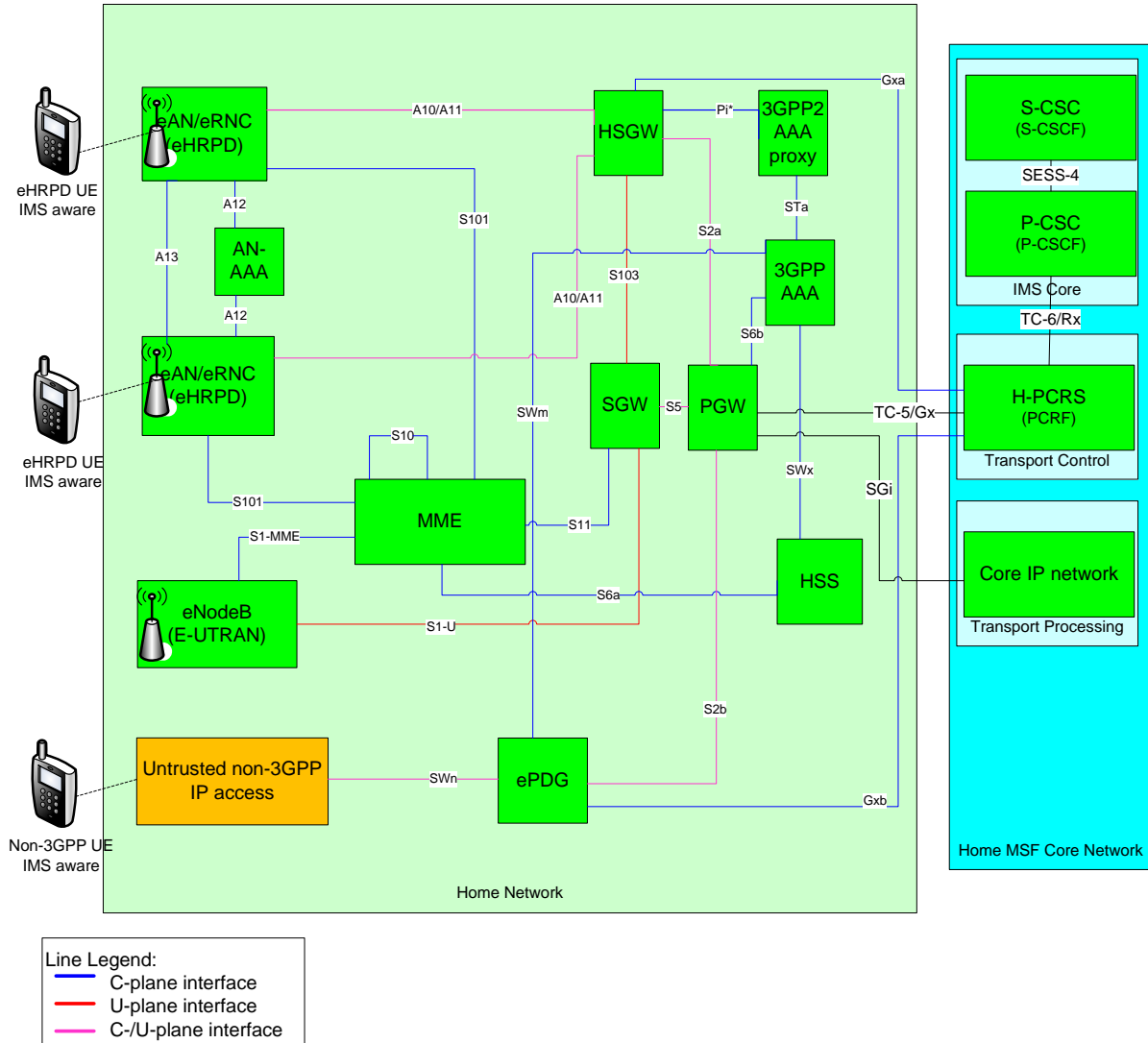

**Figure 2: Non-3GPP Access-Evolved Packet System Access Tile Architecture**

## 5. Trust Boundaries

The 3GPP2 eHRPD Access Network to the EPS access tile SHALL be in the same trust domain as the MSF core network to which it is connected. The signalling capability from the customer equipment is very limited thus restricting the ability of a user to adversely interact with the network. Within these constraints the customer equipment may also be regarded as part of the same trust domain. The IP connectivity within the eHRPD access of the EPS2 Access Tile *could* use the same address space as the core domain.

Other non-3GPP IP access to the EPS through the ePDG is an untrusted access network and should not be in the same trust domain as the MSF core network.

## 6. Element Definitions

### 6.1. eAN/eRNC

The Access Network (AN) is a logical entity in the High Rate Packet Data Radio Access Network (HRPD RAN), used for radio communications with the User Equipment (UE). An Access Network contains one or more Base Station Transceivers (BTS) and one or more Radio Network Controllers (RNC).

The evolved Access Network (eAN) is an access network which supports interworking between the 3GPP EPS and the 3GPP2 evolved HRPD RAN, in addition to legacy AN capabilities. It contains BTSs and evolved RNCs (eRNC).

The BTS is responsible to provide air interface channels for the mobile handset to listen and attach. It enables delivery of mobile broadband data services and is connected to the eRNC.

The eRNC is responsible to control radio resources for a group of BTSs and to establish, maintain, and terminate layer-2 connection to the HSGW.

The eAN/eRNC hosts the evolved Packet Control Function (ePCF) which contains the Session Control/Mobility Management (SC/MM) function, responsible for the following:

- Storage of eHRPD session related information for dormant UE.
- Assignment of UATI (Unicast Access Terminal identifier): This function assigns a new UATI to an UE.
- Access Authentication: This function performs the terminal authentication procedure. It judges whether an UE should be authenticated or not when the UE is accessing the eHRPD RAN. The SC/MM performs Point-to-Point Protocol (PPP) procedures for terminal authentication.
- Mobility Management: This function manages the location of an UE.

The eAN/eRNC communicates with a HSGW via the A10/A11 network interface as defined in the 3GPP2 A.S0017 [7], A.S0008 [11] and A.S0009 [12]. Bearers are established for both the control plane (A11) and user plane (A10).

The S101 reference point connects the eAN/eRNC with the MME in the 3GPP EPS as specified in A.S0022 [13]. This reference point provides tunneling of signaling and data between the UE and the target access network via the source/serving access network. The detailed operation of this interface is defined in TS 23.402 [18] and TS 29.276 [27].

A source eAN/eRNC communicates with a target eAN/eRNC over the A13 interface for mobility management. The A13 interface carries signaling information between the source SC/MM function and the target SC/MM function for dormant state session transfer and inter-eAN paging when the UE is in idle state

## **6.2. AN-AAA**

The Access Network-Authentication, Authorization and Accounting (AN-AAA) function in the eHRPD network is responsible to authenticate the User Equipment when it attempts to access the eHRPD RAN. The A12 interface is used to carry signaling information related to access authentication between the SC/MM function and the AN-AAA, as defined in 3GPP2 A.S0008 [11] and A.S0009 [12]. The SC/MM function supports the point-to-point protocol for the authentication procedure.

## **6.3. HSGW**

The HRPD Serving Gateway (HSGW) connects the 3GPP2 eHRPD access with the 3GPP EPC (evolved Packet Core) as a trusted non-3GPP access network. It provides interworking for multi-RAT UEs between 3GPP2 eHRPD and 3GPP EPS architecture and protocols, as specified in TS 23.402 [18]. This includes support for mobility, policy control and charging (PCC), access authentication, and roaming.

The HSGW terminates the eHRPD access network A10/A11 interface from the eAN/eRNC. It establishes, maintains and terminates link layer sessions to UEs in order to route UE-originated or UE-terminated packet data traffic towards or from the PGW in the EPC.

The HSGW supports transport layer QoS (Quality of Service) by marking data packets with DiffServ Code Point (DSCP), based on the QCI (QoS Class Identifier) of the associated EPS (Evolved Packet System) bearer.

The Gxa reference point connects the HSGW in the 3GPP2 eHRPD network to the PCRS in the 3GPP EPC. Detailed requirements and operation of this interface is defined in TS 23.203 [22], TS 29.212 [23] and TS 29.213 [44].

The HSGW provides the PMIP (Proxy Mobile IP) MAG (Mobile Access Gateway) function to support layer 3 mobility with the PGW. The S2a reference point connects the HSGW in the 3GPP2 eHRPD to the PGW in the 3GPP EPC. This reference point provides the user plane with related control and mobility support between eHRPD access and the PGW.

The S103 reference point connects the HSGW in the 3GPP2 eHRPD network with the SGW in the 3GPP EPC. The function of this bearer interface is to forward DL data between the SGW and the HSGW to minimize packet losses during mobility from E-UTRAN to eHRPD. Detailed requirements and operation of this interface is defined in TS 23.402 [18] and TS 29.276 [27]

The Pi\* reference point connects the HSGW to the 3GPP2 AAA Proxy as defined in 3GPP2 X.S0057 [9] and it is identical to the STa reference point.

## **6.4. 3GPP AAA**

The 3GPP AAA Server provides support for non-3GPP Access users with the required services, such as Authentication, Authorization and location management, in order to get

access to the EPS. It also contains necessary user related information in order to grant access to non-3GPP access.

The 3GPP AAA Server coordinates the information needed to support mobility between 3GPP and non-3GPP accesses, such as coordination of PGW information. It interacts with the HSS to maintain consistent information for users supporting mobility and service continuity between 3GPP and non-3GPP access. Details of the 3GPP AAA server operation are described in TS 23.402 [18].

The STa reference point connects the AAA in the 3GPP EPC to the AAA Proxy for 3GPP2 eHRPD access. This reference point is used to authenticate and authorize the UE and carries PMIPv6 mode related Diameter parameters between the 3GPP AAA server/proxy and the 3GPP2 AAA proxy. Detailed requirements and operation of this interface is defined in TS 23.402 [18] and TS 29.273 [39]

### **6.5. 3GPP2 AAA Proxy**

The 3GPP2 AAA proxy supports the authorization, authentication and location management function of the HSGW to access the 3GPP EPS. The 3GPP2 AAA proxy uses the STa interface to communicate with the 3GPP AAA server, and it uses the Pi\* interface to communicate with the HSGW.

### **6.6. ePDG**

The ePDG (evolved Packet Data Gateway) connects the untrusted non-3GPP access network (e.g. xDSL, WiFi and Wimax) with the 3GPP EPC.

The ePDG uses the S2b interface to communicate with the PGW and the SWm interface to communicate with the 3GPP AAA server. The PMIPv6 based S2b interface is specified in 3GPP TS 23.402 [18] and 3GPP TS 29.275 [26].

The ePDG uses the Gxb reference point to connect to the PCRS in the 3GPP EPC. Detailed requirements and operation of this interface is defined in TS 23.203 [22], TS 29.212 [23] and TS 29.213 [44].

The ePDG provides the following functions:

- Transportation of a remote IP address as an IP address specific to a PDN;
- De-capsulation/Encapsulation of packets for IPsec and PMIPv6 tunnels;
- MAG according to the PMIPv6 specification,;
- Tunnel authentication and authorization (termination of IKEv2 signalling and relay via AAA messages);
- Local mobility anchor within untrusted non-3GPP access networks using MOBIKE (if needed);

- Transport level packet marking in the uplink;
- Enforcement of QoS policies based on information received via AAA infrastructure;
- Lawful Interception.
- Allocation of GRE key, which is used to encapsulate downlink traffic to the ePDG.

## 6.7. MME

The Mobility Management Entity (MME) supports the control plane signaling from the E-UTRAN and the eHRPD. For 3GPP access, it also performs security and authentication mechanisms for the subscriber.

The MME communicates with the HSS via the S6a interface as defined within 3GPP TS 29.272 [38]. This is utilized for retrieving authentication information, storage of subscription information and location information, for 3GPP access network.

The MME also supports the S3 and S10 Interfaces which enables user and bearer information exchange for inter 3GPP access network mobility. The S3 and S10 interfaces utilize GTPv2-C as defined in 3GPP TS 29.274 [40].

Additionally the MME provides the following function to support non-3GPP access:

- eHRPD access node selection and maintenance for handovers to eHRPD network as defined in A.S0022-0 [13].
- Transparent transfer of HRPD signalling messages and transfer of status information between E-UTRAN and eHRPD access via S101 reference point, as specified in TS 23.402 [18] and TS 29.276 [27].
- Forwarding the GRE key for uplink traffic to the eAN/eRNC in case of handover to eHRPD

## 6.8. SGW

The Serving Gateway (SGW) terminates the user-plane of the E-UTRAN access (S1-U) and provides the local mobility anchor point for inter-eNodeB handover. The S1-U interface is defined within 3GPP TS 29.2811 [42]. The SGW also terminates the user-plane of the eHRPD access (S103) and provides a local non-3GPP anchor for the case of roaming when the non-3GPP access is connected to the VPLMN.

The SGW provides mobility anchoring for inter-3GPP mobility, terminating the S4 interface and relaying the traffic between 2G/3G system and the PGW.

The SGW provides packet routing and forwarding between the PGW and 3GPP access network and transport level packet marking (e.g. DSCP) in the uplink and the downlink direction. It also provides packet routing and forwarding between the PGW and non-3GPP access network.

## **6.9. PGW**

The Packet Data Network Gateway (PGW) provides interworking with packet data networks via the SGi interface, and contains routing information for attached users to route packets to/from the current SGW serving the UE for E-UTRAN access, UTRAN access, GERAN access and roaming scenarios. For eHRPD access, PGW attaches to the HSGW.

Functionality for roaming scenarios is provided using the S8 interface for both control and user plane. Control plane is provided by utilizing GTPv2-C as defined in 3GPP TS 29.274 [40], whilst user plane is provided by utilizing GTPv1-U as defined in 3GPP TS 29.281 [42]. PMIP-based S8 interface is defined in TS 23.402 [18].

When acting as a PCEF the PGW also performs UL and downlink service level charging, UL and DL service level gating control and service level rate enforcement, UL and DL bearer binding and UL bearer binding verification. This functionality is achieved by utilising the Gx interface to communicate with the PCRS as defined in 3GPP TS 29.212 [23].

## **6.10. HSS**

The Home Subscriber Server (HSS) is a central database that contains details of each subscriber that is authorized to use the 3GPP, 3GPP2 and other non-3GPP defined access networks.

The HSS contains subscription data for GPRS subscribers, HRPD subscribers, EPS subscribers and routing information. The HSS is accessible from the S4-SGSN via the S6d interface and from the MME via the S6a interface, both interfaces specified in 3GPP TS 29.272 [39]. The HSS is accessible from the HSGW via the STa/SWx interface as specified in 3GPP TS 23.402 [18]. For roaming scenarios, the HSS may be in a different PLMN than the current HSGW/MME.

The HSS also contains the authentication vectors for the S4-SGSN/MME and the HSGW to utilize during authentication procedures. Authentication of the UE occurs within the S4-SGSN/MME for 3GPP access networks, and the HSGW/AAA server for eHRPD non-3GPP access networks.

## **6.11. UE**

The User Equipment (UE) is the subscriber device supported by the 3GPP and non-3GPP access networks and is loaded with an IMS aware client. This device may support eHRPD access, ePDG access, GERAN access, UTRAN access, or E-UTRAN access to EPS.

# **7. Principles of operation**

### **7.1. E-UTRAN Attach**

A UE/user needs to register with the network to receive services that require registration. This registration is described as Network Attachment. The always-on IP connectivity for UE/users of the EPS is enabled by establishing a default EPS bearer during Network Attachment. The PCC rules applied to the default EPS bearer may be predefined in the PGW and activated in the attachment by the PGW itself. The Attach procedure may trigger one or multiple Dedicated Bearer Establishment procedures to establish dedicated EPS bearer(s) for that UE. PCC rules may also be applied to dedicated bearers or may be predefined in the PGW upon activation.

E-UTRAN Attach procedures are defined within 3GPP TS 23.401 [28].

### **7.2. GERAN/UTRAN Attach**

GERAN/UTRAN Attach procedures are as defined within [MSFR4-ARCH-3GPP-FINAL](#) [45].

### **7.3. eHRPD Attach**

eHRPD Attach procedures are defined within 3GPP2 X.S0057 [9].

### **7.4. Mobility Management and Handover within E-UTRAN**

The location of a UE idle state is known by the network on a Tracking Area List granularity. A UE in idle state is paged in all cells of the Tracking Areas in which it is currently registered. The UE may be registered in multiple Tracking Areas. All the tracking areas in a Tracking Area List to which a UE is registered, are served by the same serving MME.

An UE in registered state performs periodic Tracking Area Updates with the network after the expiry of the periodic TAU timer.

Tracking Area Update procedures are defined within 3GPP TS 23.401 [28].

The location of a UE in the connected state is known by the MME with an accuracy of a serving eNodeB ID. Mobility of the UE in this state is handled by Handover procedures. Intra E-UTRAN Handover, X2-based (eNodeB to eNodeB with potential SGW relocation) and S1-based (relocation between MME's with potential SGW relocation) are defined within 3GPP TS 23.401 [28]. Inter-RAT Handover between E-UTRAN and UTRAN/GERAN are defined within 3GPP TS 23.401 [28].

### **7.5. Mobility Management and Handover within eHRPD**

eHRPD Mobility Management and Handover procedures are defined within 3GPP2 X.S0057 [9].

### **7.6. Interworking between E-UTRAN and eHRPD**

3GPP TS 23.402 [18] defines two ways of interworking between 3GPP and non-3GPP Access Networks (ANs) connected to EPS: interworking with and without optimizations. Both mechanisms are available for interworking between E-UTRAN and eHRPD.

The non-optimized interworking is a generic method for interworking between 3GPP and any non 3GPP AN connected to EPC, and provides a basic way of maintaining the IP connectivity. The main principle is that the UE moves from one AN to the other with Attach, and the network is able to connect it to the existing sessions. This method does not assume any interfaces between the ANs, and it is not even required that the ANs have knowledge of the existence of the other ANs. The UE is in key role for making the mobility decisions.

So far interworking with optimizations has been fully standardized only in direction from E-UTRAN to eHRPD. The main principle is that simultaneous registration via both ANs is maintained by transporting eHRPD attach signaling transparently through E-UTRAN, while UE still remains attached to and in control of E-UTRAN. When it is time for UE to enter eHRPD, there is no need to perform full attach, and shorter break time can be achieved. This method includes modifications to both ANs, and additional interfaces between them. Further details about eHRPD side of operation are defined in 3GPP2 X.S0057 [9].

### **7.7. Non-Optimized Interworking**

When an interworking capable UE originally attaches to either the eHRPD or E-UTRAN, the PGW(s) that were selected to serve the UE sessions will be reported to the HSS. This will be done by the PGW itself for eHRPD Attach and by the MME in case the UE is attaching to E-UTRAN. The data about PGWs in use will be updated during the lifetime of UE session, in case there are changes in PDN connections.

When radio conditions in the UE indicate that it should move from its current AN to the other, it will leave the original AN and perform Attach to the other AN, with a Handover Attach indication. The Attach procedure is performed normally, including Authentication and Authorization of the UE sessions, as defined in 3GPP TS 23.402 [18] and 3GPP2 X.S0057 [9], with the only difference being that the existing PGW(s) will be selected to preserve the UE sessions. The Attach signaling always reaches the HSS, and if selected PGW(s) are stored there, it will report them to the new AN, so the new AN can find the right PGW(s). Also PGW receives indication that this is Handover Attach, so it will find the existing sessions for this UE and connects them to the new AN.

The non-optimized interworking method can be used both in active and idle state.

### **7.8. Optimized Interworking**

The optimized interworking is applicable only for the direction from E-UTRAN to eHRPD. It consists of two phases, the pre-registration and session maintenance phase, and the actual handover or mobility phase.

In the Pre-registration and session maintenance phase the UE remains attached to E-UTRAN, and it will receive information from the serving eNB that it should perform tunneled pre-registration to eHRPD. This signaling, which consists of normal eHRPD Attach

messages, is routed through a tunnel that is created from the UE transparently through the E-UTRAN and EPC nodes to the eHRPD AN. The tunnel goes through eNB to MME via S1 interface, and from MME it crosses over to the eHRPD AN via the S101 interface. In addition to Attach, the tunnel is used to create and maintain sessions in eHRPD that match with those that are in use in E-UTRAN. This creates a dormant session for the UE in the eHRPD AN.

When the UE is in Active State, the network will control its mobility, and it will guide it to make measurements of the neighboring cells, both E-UTRAN and eHRPD when applicable. If the serving eNB decides based on the radio measurements that handover to eHRPD should be made, it will command the UE to start preparing the handover. Using the tunnel to eHRPD AN, the UE will request traffic channel from the eHRPD AN. The eHRPD AN constructs the information necessary for the UE to make an access to it, and signals it back to the UE and the eNB commands the UE to make the Handover. The UE can access eHRPD very quickly because it has exact information for accessing the eHRPD cell, and the eHRPD AN has the UE context, and is ready to receive it without need for time consuming Attach signaling.

When the UE is in Idle State, it will monitor the radio conditions of the available ANs, and it may autonomously decide to perform cell re-selection to eHRPD. The UE session created during pre-registration and session maintenance state is found, and the UE may start performing according to eHRPD dormant mode operation without performing full attach.

## **7.9. Location Based Services**

Location Based services for EPS are currently not defined within 3GPP Release 8, and are therefore FFS.

## **8. External Reference points**

The User Equipment is connected over the air interface to the RAN and eHRPD Access Network that is capable of connecting to an IMS enabled network. To access the IMS network the customer equipment needs to be provisioned with an IMS aware client / configuration.

When the user attaches to the network it is authenticated by the HSS by using the SWx/STa interface. The user is also authenticated by the HSS located in the IMS network over the SESS-2, SESS-4, Cx interfaces

Application level session information is downloaded by the P-CSC to the PCRS via the Rx Interface. This information is utilized by the PCRS in order to exchange PCC rules with the PGW, over the Gx interface, in order to enforce the policy.

Since this access tile supports IP connectivity to the customer it can support IP enabled services like Presence, IPTV, Instant Messaging, VoIP etc...

The 3GPP/non-3GPP EPS2 Access tile supports IP transport (TR-0) towards the Core

Interface Designation	3GPP Equivalent	Description	Protocol	MSF IA
<b>Transport Interfaces</b>				
TR-0	SGi	IP Interconnect to/from the core	N/A	N/A
<b>Session Signalling</b>				
SESS-2	Gm	SIP Protocol for session initiation	SIP	MSF-IA-SIP.016-FINAL
<b>Bandwidth management</b>				
TC-5	Gx	Between PGW and PCRS for Policy rules enforcement in 3GPP EPS networks	Diameter	N/A

## 9. Internal Reference points

Interface Designation	3GPP Equivalent	Description	Protocol	MSF IA
<b>3GPP/non-3GPP2 EPS2 access tile</b>				
	A10/A11	Between eAC/eRNC and HSGW for transfer of signalling and bearer information	MIPv4	Currently not specified
	A12	Between eAC/eRNC and AN-AAA for user authentication and transfer of billing data	RADIUS	Currently not specified
	A13	Between two eAN/eRNC's to address mobility handoffs	MIPv4	Currently not specified
	S101	Between eAN/eRNC and MME for transfer of control plane information	S101-AP	Currently not specified
	S103	Between HSGW and SGW for transfer of user plane	GRE Tunneling	Currently not specified
	S2a	Between HSGW and PGW for control and mobility support of eHRPD access to EPS	PMIPv6	Currently not specified
	S2b	Between the ePDG and the PGW for untrusted non-3GPP access network connectivity to EPS	PMIPv6	Currently not specified
	Pi*	Between HSGW and 3GPP2 AAA Proxy for authentication, authorization	Diameter	Currently not specified

		and location management		
	STa	Between the 3GPP AAA and the 3GPP2 AAA Proxy for authentication, authorization and location management	Diameter	Currently not specified
	SWm	Between the 3GPP AAA and the ePDG for authentication, authorization and location management	Diameter	Currently not specified
	SWn	Between the Untrusted Non-3GPP IP Access and the ePDG for both C-plane and U-plane traffic	Diameter	Currently not specified
	SWx	Between the 3GPP AAA and the HSS for authentication, authorization and location management	Diameter	Currently not specified
	S6a	Between the MME and HSS for user authentication, access to user subscription data, and location update.	Diameter	Currently not specified
	S6b	Between the 3GPP AAA and the PGW for authentication, authorization and location management	Diameter	Currently not specified
	S5	Between SGW and the PGW for control plane and user plane connectivity	GTPv2-C GTPv1-U	Currently not specified
	S10	Between MME's for mobility handoff's	GTPv2-C	Currently not specified
	S11	Between MME and SGW for control plane connectivity	GTPv2-C	Currently not specified
	Gxa	Between the PCRS and the HSGW	Diameter	Currently not specified
	Gxb	Between the PCRS and the ePDG	Diameter	Currently not specified

--- End of Document ---