



**VoLTE Interoperability Event Testing
Scenarios
MSF-VoLTE-SCN-002.FINAL**

Multiservice Switching Forum

Contribution Number: msf2010.111.05

Filename: MSF-VoLTE-SCN-002.FINAL

Last Saved: **01/13/2012 17:01 A1/P1**

Working Group: **Architecture, Protocol and Control, Interop**

Title: **VoLTE Interoperability Event Testing Scenarios**

Source: **David Hutton**

Vodafone
david.hutton@vodafone.com

Abstract:

This document describes a set of physical scenarios to test the interoperability between key components of the LTE architecture and IMS service layer as part of a VoLTE interoperability event. The interfaces to be tested are specified (in terms of references to the appropriate 3GPP specifications) within this document such that additional implementation agreements for the individual interfaces need not be created. The tests cases are described at a high level, more detailed test plans will be created from these.

By submitting this contribution, the representative(s) of the source company(ies) acknowledge reading and agrees to the MSF IPR Policy Statement.

The Multiservice Switching Forum (MSF) is responsible for developing Implementation Agreements or Architectural Frameworks which can be used by developers and network operators to ensure interoperability between components from different vendors. MSF Implementation Agreements are formally ratified via a Straw Ballot and then a Principal Member Ballot.

Draft MSF Implementation Agreements or Architectural Framework may be published before formal ratification via Straw or Principal Member Ballot. In order for this to take place, the MSF Technical Committee must formally agree that a draft Implementation Agreement or Architectural Framework should be progressed through the balloting process. A Draft MSF Implementation Agreement or Architectural Framework is given a document number in the same manner as an Implementation Agreement.

Draft Implementation Agreements may be revised before or during the full balloting process. The revised document is allocated a new major or minor number and is published. The original Draft Implementation Agreement or Architectural Framework remains published until the Technical Committee votes to withdraw it.

After being ratified by a Principal Member Ballot, the Draft Implementation Agreement or Architectural Framework becomes final. Earlier Draft Implementation Agreements or Architectural Frameworks remain published until the Technical Committee votes to withdraw them.

DISCLAIMER

The information in this publication is believed to be accurate as of its publication date. Such information is subject to change without notice and the Multiservice Switching Forum is not responsible for any errors or omissions. The Multiservice Switching Forum does not assume any responsibility to update or correct any information in this publication. Notwithstanding anything to the contrary, neither the Multiservice Switching Forum nor the publisher make any representation or warranty, expressed or implied, concerning the completeness, accuracy, or applicability of any information contained in this publication. No liability of any kind whether based on theories of tort, contract, strict liability or otherwise, shall be assumed or incurred by the Multiservice Switching Forum, its member companies, or the publisher as a result of reliance or use by any party upon any information contained in this publication. All liability for any implied or express warranty of merchantability or fitness for a particular purpose is hereby disclaimed.

The receipt or any use of this document or its contents does not in any way create by implication or otherwise:

Any express or implied license or right to or under any Multiservice Switching Forum member company's patent, copyright, trademark or trade secret rights which are or may be associated with the ideas, techniques, concepts or expressions contained herein; nor

Any warranty or representation that any Multiservice Switching Forum member companies will announce any product(s) and/or service(s) related thereto, or if such announcements are made, that such announced product(s) and/or service(s) embody any or all of the ideas, technologies, or concepts contained herein; nor

Any commitment by a Multiservice Switching Forum company to purchase or otherwise procure any product(s) and/or service(s) that embody any or all of the ideas, technologies, or concepts contained herein; nor

Any form of relationship between any Multiservice Switching Forum member companies and the recipient or user of this document.

Implementation or use of specific Multiservice Switching Forum Implementation Agreements, Architectural Frameworks or recommendations and Multiservice Switching Forum specifications will be voluntary, and no company shall agree or be obliged to implement them by virtue of participation in the Multiservice Switching Forum.

For addition information contact:

Multiservice Switching Forum

48377 Fremont Blvd, Suite 117,

Fremont, CA 94538

(510) 492-4050

(510) 492-4001 (fax)

info@msforum.org

WWW.MSFORUM.ORG

© Multiservice Switching Forum 2011 (or current year)

1	INTRODUCTION	6
1.1	TEST SCENARIOS	10
2	TESTING SCENARIOS	11
2.1	SCENARIO 1 – BASIC INTEROPERABILITY	11
2.1.1	<i>Network Components</i>	12
2.1.1.1	Scenario 1a	12
2.1.1.2	Scenario 1b	12
2.1.2	<i>Protocols and Reference Points</i>	12
2.1.3	<i>Test Cases</i>	13
2.1.3.1	Scenario 1a	13
2.1.3.2	Scenario 1b	13
2.2	SCENARIO 2 – ROAMING AND INTERCONNECT	14
2.2.1	<i>Network Components</i>	15
2.2.1.1	Scenario 2a	15
2.2.1.2	Scenario 2b	16
2.2.2	<i>Protocols and Reference Points</i>	16
2.2.3	<i>Test Cases</i>	17
2.2.3.1	Scenario 2a	17
2.2.3.2	Scenario 2b	17
2.3	SCENARIO 3 – NON-LTE ACCESS	18
2.3.1	<i>Network Components</i>	19
2.3.1.1	Scenario 3a	19
2.3.1.2	Scenario 3b	20
2.3.2	<i>Protocols and Reference Points</i>	20
2.3.3	<i>Test Cases</i>	20
2.4	SCENARIO 4 – HANDOVERS	21
2.4.1	<i>Network Components</i>	22
2.4.1.1	Scenario 4a	22
2.4.1.2	Scenario 4b	22
2.4.1.3	Scenario 4c	23
2.4.2	<i>Protocols and Reference Points</i>	23
2.4.3	<i>Test Cases</i>	23
2.5	SCENARIO 5 – SELF-ORGANISING NETWORKS	25
2.5.1	<i>Network Components</i>	25
2.5.1.1	Scenario 5a	25
2.5.2	<i>Protocols and Reference Points</i>	25
2.5.3	<i>Test Cases</i>	26
3	INTERFACE SPECIFICATIONS	27
3.1	LTE-Uu (UE – eNODEB)	27
3.2	S1-MME (UE – MME)	27
3.3	S1AP (eNODEB-MME)	27
3.4	S1-U (eNODEB - S-GW)	27
3.5	X2 (eNODEB – eNODEB)	27
3.6	S3 (S4 SGSN – MME)	27
3.7	S4 (S4 SGSN – S-GW)	27
3.8	S5 (S-GW - P-GW)	27
3.9	S6A (HSS – MME)	27
3.10	S6B (P-GW – 3GPP AAA)	27
3.11	S6D (HSS – S4 SGSN)	27
3.12	S8 (S-GW – P-GW)	27
3.13	S9 (PCRF – PCRF)	27
3.14	S10 (MME – MME)	27
3.15	S11 (MME – S-GW)	27
3.16	S12 (UTRAN – S-GW)	28
3.17	Gx (PCRF – P-GW)	28
3.18	Rx (PCRF - IP APPLICATION [P-CSCF FOR IMS])	28
3.19	GR (SGSN – HSS)	28

3.20	Gn (SGSN – MME / SGSN – P-GW).....	28
3.21	Gm (UE – P-CSCF).....	28
3.22	Mw (X-CSCF – X-CSCF).....	28
3.23	ISC (S-CSCF – AS)	28
3.24	Ut (UE – AS).....	28
3.25	SGi (EPC BASED PLMN AND ANOTHER PACKET DATA NETWORK)	28
4	GSMA PERMANENT REFERENCE DOCUMENTS (PRDS).....	29
4.1	IR.65: IMS ROAMING & INTERWORKING GUIDELINES	29
4.2	IR.88: LTE ROAMING GUIDELINES.....	29
4.3	IR.92: IMS PROFILE FOR VOICE AND SMS.....	29

1 Introduction

The Voice over LTE architecture is based on GSMA's recommendations IR.65 "IMS Roaming & Interworking Guidelines", IR.88 "LTE Roaming Guidelines" and IR.92 "IMS Profile for Voice and SMS". The GSMA recommendations are based on the 3GPP defined architecture for Long Term Evolution (LTE), Evolved Packet Core network (EPC), and the IMS Core Network.

- **Radio Access Network.** The Evolved Universal Terrestrial Radio Access Network (E-UTRAN); this is often referred to as 3G Long Term Evolution (LTE).
- **Core Network.** The Evolved Packet Core (EPC), this is often referred to as the System Architecture Evolution (SAE).
- **IMS Core Network.** The IMS Core Network within the VoLTE architecture provides the service layer for providing voice services using Multimedia Telephony.

The figure below shows the main components of the VoLTE in the non-roaming configuration.

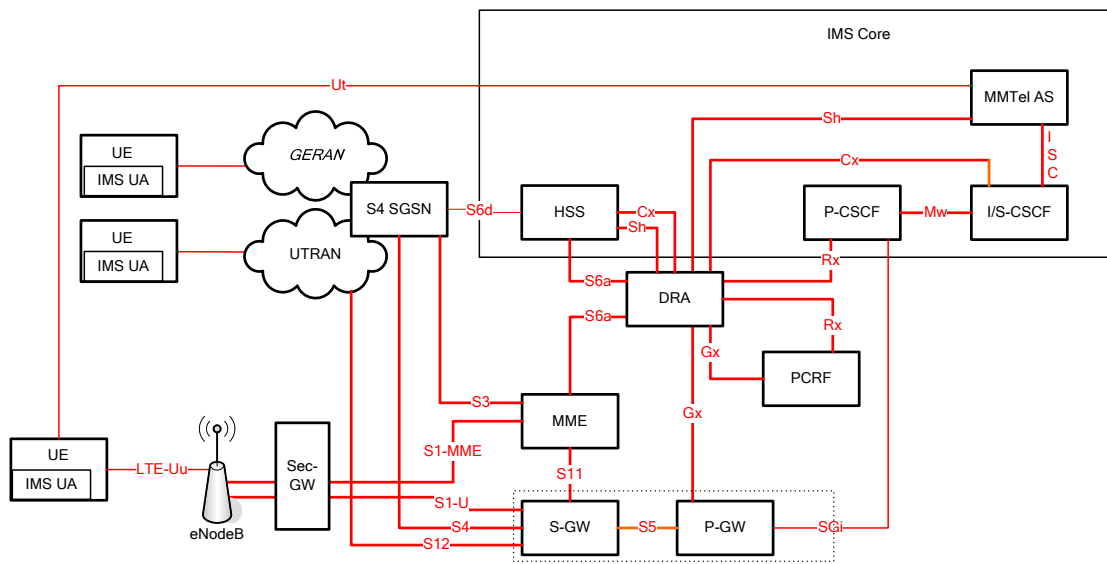

Figure 1 - VoLTE Architecture

The main components of the Architecture are described below.

- **UE (User Equipment).** The User Equipment that is used to connect to the EPS, in the figure above this is an LTE capable UE accessing EPS via the LTE-Uu radio interface.
- **eNodeB.** The evolved RAN (E-UTRAN) consists of a single node, the eNodeB that interfaces with the UE. The eNodeB hosts the Physical (PHY), Medium Access Control (MAC), Radio Link Control (RLC), and Packet Data Convergence Protocol (PDCP) layers that include the functionality of user-plane header-compression and encryption. It also offers Radio Resource Control (RRC) functionality corresponding to the control plane. It performs many functions including radio resource management, admission control, scheduling, enforcement of negotiated UL QoS, cell information broadcast, ciphering/deciphering of user and control plane data, and compression/decompression of DL/UL user plane packed headers.
- **MME (Mobility Management Entity).** The Mobility Management Entity (MME) is the key control-node for the LTE access-network. It is responsible for idle mode UE tracking and paging procedures including retransmissions. It is involved in the bearer activation / deactivation process and is also responsible for choosing the S-GW (see below) for the UE at the initial attach and at time of intra-LTE handover involving Core Network node relocation. It is responsible for authenticating the user (in conjunction with the HSS). The NAS (Non-

Access Stratum) signalling terminates at the MME which is also responsible for the generation and allocation of temporary identities to the UEs. The MME validates the permission of the UE to camp on the service provider's PLMN (Public Land Mobile Network) and enforces UE roaming restrictions. The MME is the termination point in the network for ciphering/integrity protection for NAS signalling and handles security key management. Lawful interception of signalling is also a function provided by the MME. The MME provides the control plane function for mobility between LTE and 2G/3G access networks and interfaces with the home HSS for roaming UEs.

- **S-GW (Serving Gateway).** The S-GW routes and forwards user data packets, while also acting as the mobility anchor for the user plane during inter-eNodeB handovers and as the anchor for mobility between LTE and other 3GPP technologies (terminating S4 interface and relaying the traffic between 2G/3G systems and PDN GW). For idle state UE, the S-GW terminates the DL data path and triggers paging when the DL data arrives for the UE. It manages and stores UE contexts and performs replication of the user traffic in case of lawful interception. It is likely that the S-GW and P-GW functions would be realized as a single network element.
- **P-GW (Packet Data network GateWay).** The P-GW provides connectivity between the UE and external packet data networks, it provides the entry and exit point of traffic for the UE. A UE may have simultaneous connectivity with more than one P-GW for accessing multiple Packet Data Networks. The P-GW performs policy enforcement, packet filtering for each user, charging support, lawful interception and packet screening. The P-GW also acts as the anchor for mobility between 3GPP and non-3GPP technologies such as WiMAX or DSL. It is likely that the S-GW and P-GW functions would be realized as a single network element.
- **PCRF (Policy Charging and Rules Function).** The PCRF provides policy control decisions and flow based charging controls. The PCRF determines how a service data flow shall be treated in the enforcement function (P-GW in this case) and ensure that the user plane traffic mapping and treatment is in accordance with the user's profile.
- **HSS (Home Subscriber Server).** The HSS is a network database that holds both static and dynamic data elements related to subscribers. The HSS provides user profile information to the MME during user authentication.
- **S4-SGSN (Serving GPRS Support Node).** The SGSN supports the legacy access for UTRAN and GERAN. In the EPS architecture (3GPP release 8) the SGSN is enhanced to support the S4 and S3 interfaces (hence referred to as the S4 SGSN). The S4 interface provides control and mobility support between GPRS Core and the 3GPP Anchor function of the Serving GW. The S3 interface enables user and bearer information exchange for inter 3GPP access network mobility.
- **P-CSCF (Proxy Call Session Control Function).** The P-CSCF is the initial point of contact for session signaling for the IMS-enable VoLTE UE. The P-CSCF behaves as a SIP proxy by forwarding SIP messages the UE and the IMS Core Network, maintains the security associations between itself and the VoLTE UE, incorporates the Application Function aspect of PCC to enable binding of the IMS session with the bearer for applying dynamic policy and receiving notifications of bearer level events.
- **I/S-CSCF (Interrogating/Serving Call Session Control Function).** The I-CSCF is the contact point within an operator's network for all connections destined to a user of that network. On IMS Registration, it interrogates the HSS to determine which suitable S-CSCF to route the request for registration. For Mobile Terminating calls, it interrogates the HSS to determine which S-CSCF the user is registered on. The S-CSCF provides session set-up, session tear-down, session control and routing functions. It generates records for billing purposes for all sessions under its control, and invokes applications using Application Servers. The S-CSCF acts as SIP registrar for VoLTE UE's that the HSS and I-CSCF assign to it. It queries the HSS for the applicable subscriber profiles

and handles calls involving these end points once they have been registered. The S-CSCF uses subscription information to determine the appropriate onward routing for calls originating through it.

- **MMTel AS (Multimedia Telephony Application Server).** The MMTel AS is an IMS Application Server providing support for multimedia telephony services as defined by 3GPP e.g. supplementary service functionality.
- **Sec-GW (Security Gateway).** The Sec-GW is used to originate and terminate secure associations between the eNodeB and the Evolved Packet Core network. IPsec tunnels are established with pre-shared security keys, which can take a number of different formats. IPsec tunnels enforce traffic encryption, for added protection, according to the parameters exchanged between the two parties during tunnel setup. This enables secure communications between the eNodeB and EPC across the S1-MME, S1-U and X2 interfaces.
- **DRA (Diameter Routing Agent).** The Diameter Routing Agent defined by 3GPP and GSMA, is a new network element that controls Diameter signalling, enabling the seamless communication and control of information between network elements within LTE or IMS networks and across LTE network borders. A DRA reduces the mesh of Diameter connections that negatively impacts network performance, capacity and management.

The main interfaces of the Architecture are described below.

- **LTE-Uu.** The radio interface between the eNodeB and the User Equipment. Interoperability of this interface is out of scope for the scenarios described in this document and is covered by the work of other organizations, principally LSTI (www.lstiforum.org).
- **S1-MME.** The control plane interface between EUTRAN and MME. The protocols used over this interface are the Non-access stratum protocols (NAS).
- **S1-U.** The interface between EUTRAN and the S-GW for per-bearer user plane tunnelling and inter-eNodeB path switching during handover. The transport protocol over this interface is GPRS Tunnelling Protocol-User plane (GTPv1-U).
- **S3.** The interface between the S4-SGSN and the MME enabling user and bearer information exchange for inter 3GPP access network mobility. The protocol used on the S3 interface is GPRS Tunnelling Protocol-Control plane (GTPv2-C).
- **S4.** The interface between the S4-SGSN and the S-GW providing user plane and related control and mobility support. The protocols used on the S4 interface are GPRS Tunnelling Protocol-Control plane (GTPv2-C) and is GPRS Tunnelling Protocol-User plane (GTPv1-U).
- **S5.** The interface provides user plane tunnelling and tunnel management between S-GW and P-GW. It is envisaged that the S-GW and P-GW may be realized as single network element in which case the S5 interface is not exposed. For the test scenarios described within this document. The protocol used on the S5 interface is GTPv1-U/GTPv2-C.
- **S6a.** The interface enables the transfer of subscription and authentication data for authenticating/authorizing user access. The protocol used on the S6a interface is Diameter.
- **S10.** The interface provides for MME – MME information transfer and is used to enable MME relocation. The protocol used on the S10 interface is GPRS Tunnelling Protocol-Control plane (GTPv2-C).
- **S11.** The interface between the MME and S-GW. The protocol used on the S11 interface is GPRS Tunnelling Protocol-Control plane (GTPv2-C).

- **S12.** The interface between the legacy UTRAN and the S-GW for user plane tunnelling when direct tunnel is established. The protocol used on the S12 interface is GPRS Tunnelling Protocol-User plane (GTPv1-U). Usage of the S12 interface is an operator configuration option.
- **Gx.** The interface between the PCRF and the P-GW, allowing the PCRF direct control over the policy enforcement functions of the P-GW. The protocol used on the Gx interface is Diameter.
- **Rx.** The interface between the appropriate Application Function (the P-CSCF in the case of IMS) and the PCRF allowing the Application Function to request the application of an appropriate policy for a session. The protocol used on the Rx interface is Diameter.
- **SGi.** The interface between the P-GW and the Packet Data Network which can be an operator external public or private packet data network or an intra operator packet data network (e.g. for provision of IMS services).

1.1 Test Scenarios

This document describes five test scenarios that will be used to exercise interoperability of the key interfaces of the EPS architecture these being:-

Basic Interoperability. In this scenario a single instance of the EPS architecture will be created using components from different vendors. Testing will include attachment and detachment from the network, Tracking Area Update, IP-CAN session establishment, SIP registration (to IMS), SIP session establishment, interaction with IMS Multimedia Telephony, and MME pooling. This scenario focuses on testing interoperability of the functionality as profiled by GSMA PRD IR.92.

Roaming and Interconnect. In this scenario the different roaming and interconnect scenarios are tested including the local breakout model with visited P-CSCF and home operator applications. The test set will be the same as for the Basic Interoperability case (with the exception of MME pooling). This scenario focuses on testing interoperability of the functionality as profiled by GSMA PRD IR.65, GSMA PRD IR.88 and GSMA PRD IR.92.

Non-LTE Access. In this scenario, the 'legacy' 3GPP access types of UMTS (UTRAN) and GSM/EDGE (GERAN) are used to interface to the EPC. The test set will be the same as for the Basic Interoperability case (with the exception of MME pooling).

Handover. In this scenario the different handover scenarios are tested, this will include handover between eNodeBs, MME/S-GW relocation and handover between LTE and legacy 3GPP (UMTS, GSM/EDGE) access.

Self-Organising Networks. In this scenario the focus on the S1 and X2 interface aspects of Self-Organising Networks are tested. This shall include aspects of Self Configuration (Dynamic configuration of the S1-MME interface, Dynamic Configuration of the X2 interface) and support of Automatic Neighbour Recognition within the UE and eNodeB.

Figure 3 - Scenario 1b Physical Architecture – MME Pooling

NOTE: Diameter Routing Agent and Security Gateway are not displayed in the figure but are applied to the architecture.

2.1.1 Network Components

2.1.1.1 Scenario 1a

The following components are required for this scenario.

- Two LTE UE's with IMS User Agents
- One eNodeB
- One MME
- One S-GW
- One P-GW
- One PCRF
- One HSS
- One P-CSCF
- One I/S-CSCF
- One MMTel Application Server
- One Sec-GW
- One DRA

2.1.1.2 Scenario 1b

The following components are required for this scenario.

- One LTE UE
- One eNodeB
- Two or more MME's configured in a pool.
- One S-GW
- One P-GW
- One PCRF
- One HSS
- One Sec-GW
- One DRA

2.1.2 Protocols and Reference Points

The following reference points will be interoperated in this scenario.

Interface	Protocol	Sub Scenario
S1-MME	NAS	1a, 1b
S1-U	GTPv1-U	1a, 1b
S5	GTPv1-U/GTPv2-C	1a, 1b
S10	GTPv2-C	1b
S11	GTPv2-C	1a, 1b
S6a	Diameter	1a
Gx	Diameter	1a
Rx	Diameter	1a
Gm	IMS SIP	1a
Mw	IMS SIP	1a
ISC	IMS SIP	1a
Ut	XCAP	1a

2.1.3 Test Cases

2.1.3.1 Scenario 1a

The following tests will be executed in order to verify interoperability of the indicated interfaces between different vendors. This scenario focuses on the verification of the functionality profiled within GSMA PRD IR.92.

- LTE UE Attach (IP-CAN Session Establishment)
- Tracking Area Update
- LTE UE Detach (IP-CAN Session Tear Down)
- IMS UA Registration (via LTE UE)
- IMS Voice Session Establishment (LTE UE to LTE UE)
- IMS Voice Session Termination
- MMTel Supplementary Service Interaction and Configuration

2.1.3.2 Scenario 1b

The following tests will be executed in order to verify interoperability of the indicated interfaces between different vendors.

With a multi-vendor pool (pool of MME instances from different vendors)

- LTE UE Attach (IP-CAN Session Establishment) with load balancing across pool.
- LTE UE Detach (IP-CAN Session Tear Down)

2.2 Scenario 2 – Roaming and Interconnect

The Roaming test scenario represents the test architecture where two subscribers, of the same Operator, perform and end to end call whilst one subscriber is in the HPLMN and the other is roaming in a VPLMN. The roaming subscriber attaches in the visited network where local breakout is applied, a Visited P-CSCF and home IMS services as depicted in Figure 4.

The Interconnect test scenario is where two subscribers, of different operators, perform an end to end call whilst in their respective PLMN's, as depicted in Figure 5.

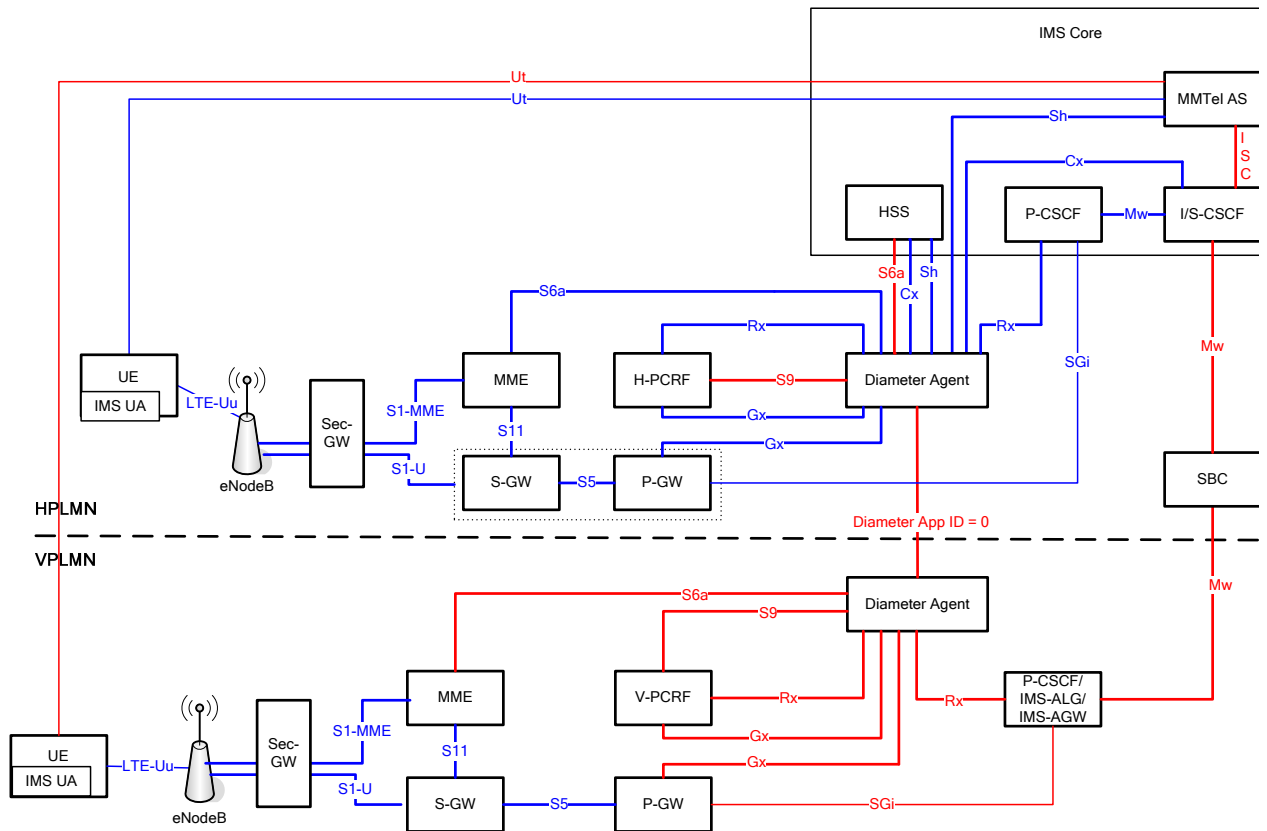

Figure 4 - Scenario 2a Roaming with Local Breakout, Visited P-CSCF and home routed IMS traffic.

NOTE: The Gm interface (UE to P-CSCF) is a focus for testing although not shown in the above figure.

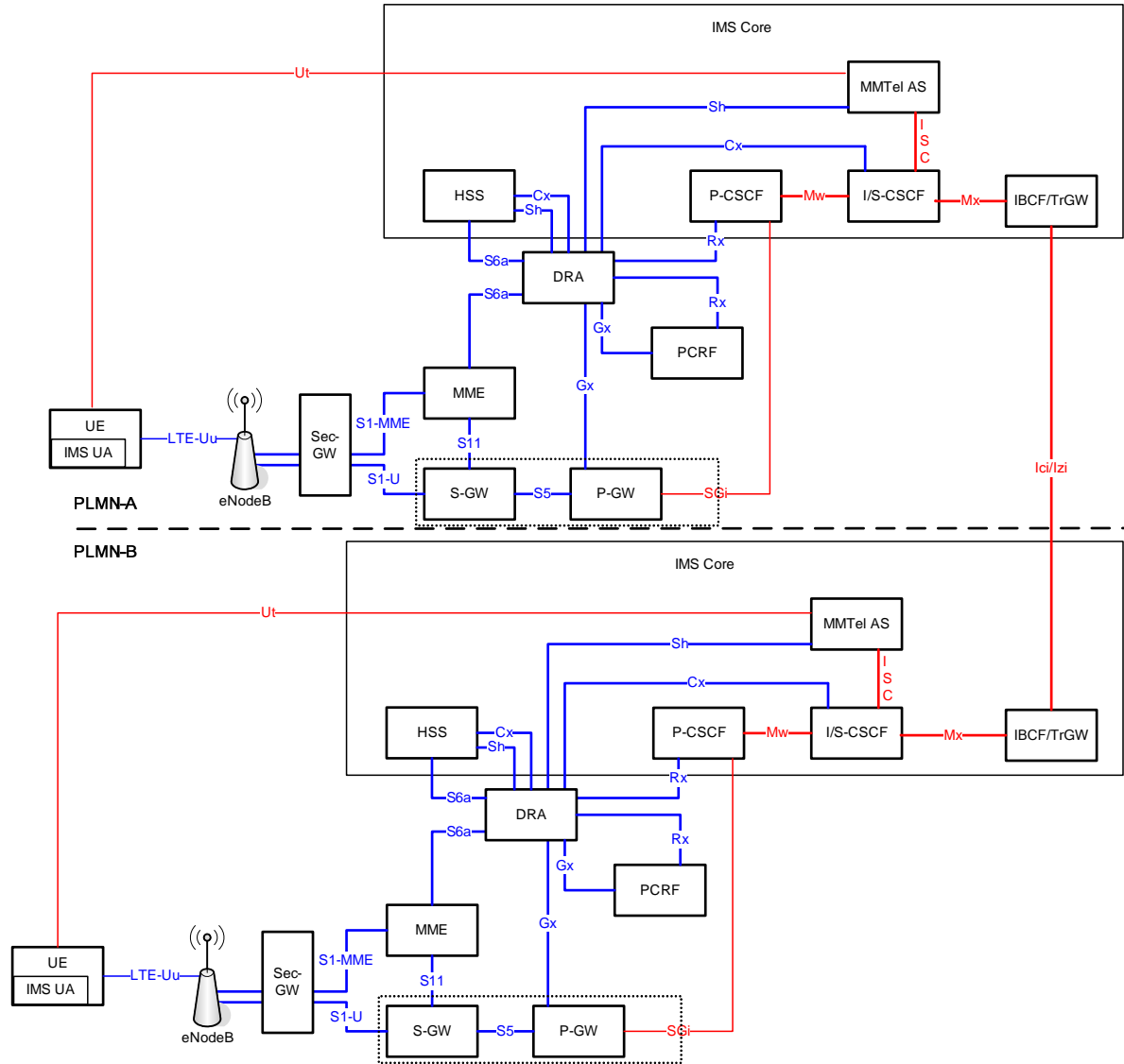

Figure 5 - Scenario 2b Interconnect between two subscribers in their Home PLMNs

NOTE: The Gm interface (UE to P-CSCF) is a focus for testing although not shown in the above figure.

NOTE: The IBCF/TrGW may be a single physical node, or two separate nodes utilising the Ix Interface. Although, Ix is not within scope of testing.

2.2.1 Network Components

2.2.1.1 Scenario 2a

In the Visited Network

- One LTE UE with IMS User Agent
- One eNodeB
- One MME
- One S-GW
- One P-GW
- One PCRF
- One P-CSCF/IMS-ALG/IMS-AGW

- One DRA
- One Sec-GW

In the Home Network

- One LTE UE with IMS User Agent
- One eNodeB
- One MME
- One S-GW
- One P-GW
- One PCRF
- One Session Border Controller
- One DRA
- One HSS
- One P-CSCF
- One I/S-CSCF
- One MMTel Application Server
- One Sec-GW

2.2.1.2 Scenario 2b

In the PLMN-A

- One LTE UE with IMS User Agent
- One eNodeB
- One MME
- One S-GW
- One P-GW
- One PCRF
- One P-CSCF
- One HSS
- One I/S-CSCF
- One MMTel Application Server
- One IBCF/TrGW
- One Sec-GW
- One DRA

In the PLMN-B

- One LTE UE with IMS User Agent
- One eNodeB
- One MME
- One S-GW
- One P-GW
- One PCRF
- One P-CSCF
- One HSS
- One I/S-CSCF
- One MMTel Application Server
- One IBCF/TrGW
- One Sec-GW
- One DRA

2.2.2 Protocols and Reference Points

The following reference points will be interoperated in this scenario.

Interface	Protocol	Sub-Scenarios
S6a	Diameter	2a
S9	Diameter	2a
Rx	Diameter	2a

Gx	Diameter	2a
Gm	IMS SIP	2a, 2b
Mw	IMS SIP	2a, 2b
ISC	IMS SIP	2a, 2b
Ut	XCAP	2a
Mx	IMS SIP	2b
Ici	IMS SIP	2b
Izi	RTP	2b

2.2.3 Test Cases

2.2.3.1 Scenario 2a

The following tests will be executed in order to verify interoperability of the indicated interfaces between different vendors. This scenario focuses on the verification of the functionality profiled within GSMA PRD IR.88 and GSMA PRD IR.92.

- LTE UE Attach in Visited Network (IP-CAN Session Establishment)
- LTE UE Detach in Visited Network (IP-CAN Session Tear Down)
- IMS UA Registration from Visited Network (via LTE UE)
- IMS Voice Session Establishment (between LTE UE in Home Network and LTE UE in Visited Network)
- IMS Voice Session Termination
- MMTel Supplementary Service Interaction and Configuration for LTE UE in Visited Network

2.2.3.2 Scenario 2b

The following tests will be executed in order to verify interoperability of the indicated interfaces between different vendors. This scenario focuses on the verification of the functionality profiled within GSMA PRD IR.65 and GSMA PRD IR.92.

- IMS Voice Session Establishment (LTE UE to LTE UE)
- IMS Voice Session Termination
- MMTel Supplementary Service Interaction

2.3 Scenario 3 – Non-LTE Access

The Non-LTE 3GPP Access test case can be realized in two different ways depending upon the compliance or otherwise of the SGSN. The two different realizations are shown in the figure below.

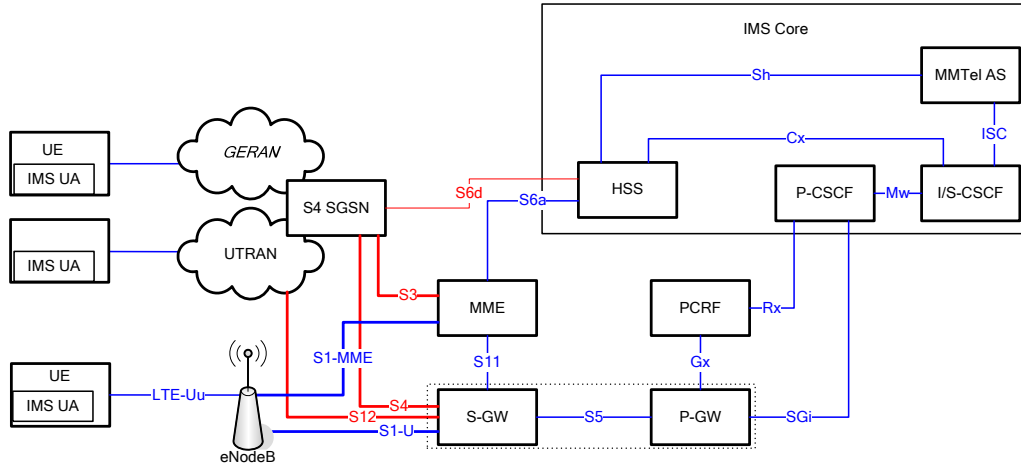

Figure 6 - Scenario 3a. Non LTE 3GPP Access with S4 SGSN

NOTE: Diameter Routing Agent and Security Gateway are not displayed in the figure but are applied to the architecture.

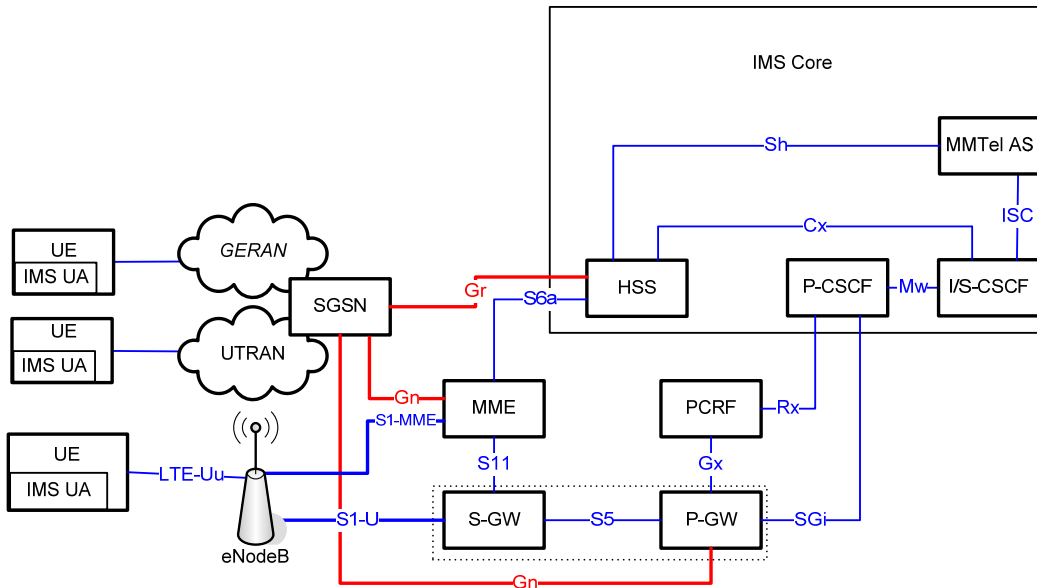

Figure 7 - Scenario 3b. Non LTE 3GPP Access with legacy SGSN

NOTE: Diameter Routing Agent and Security Gateway are not displayed in the figure but are applied to the architecture.

2.3.1 Network Components

2.3.1.1 Scenario 3a

- One UTRAN with IMS UA
- One GERAN UE with IMS UA
- One LTE UE with IMS UA
- UTRAN access infrastructure
- GERAN Access Infrastructure
- One eNodeB
- One S4 SGSN
- One MME
- One S-GW
- One P-GW
- One PCRF
- One HSS
- One P-CSCF
- One I/S-CSCF
- One MMTel Application Server
- One Sec-GW
- One DRA

-

2.3.1.2 Scenario 3b

- One UTRAN UE with IMS UA
- One GERAN UE with IMS UA
- One LTE UE with IMS UA
- UTRAN access infrastructure
- GERAN access infrastructure
- One eNodeB
- One Legacy SGSN
- One MME
- One S-GW
- One P-GW
- One PCRF
- One HSS
- One P-CSCF
- One I/S-CSCF
- One MMTel Application Server
- One Sec-GW
- One DRA

2.3.2 Protocols and Reference Points

The following reference points will be interoperated in this scenario.

Interface	Protocol	Sub-Scenarios
S3	GTPv2-C	3a
S4	GTPv2-C (control plane) / GTPv1-U (user plane)	3a
S6d	Diameter	3a
S12	GTPv1-U	3a
Gr	MAP	3b
Gn	GTPv1	3b

2.3.3 Test Cases

The following tests will be executed for both scenarios in order to verify interoperability of the indicated interfaces between different vendors.

- UTRAN UE Attach (IP-CAN Session Establishment)
- GERAN UE Attach (IP-CAN Session Establishment)
- UTRAN UE Detach (IP-CAN Session Tear Down)
- GERAN UE Detach (IP-CAN Session Tear Down)
- IMS UA Registration (via UTRAN UE)
- IMS UA Registration (via GERAN UE)
- IMS Voice Session Establishment (combination of GERAN, UTRAN and LTE UE's)
- IMS Voice Session Termination (combination of GERAN, UTRAN and LTE UE's)
- MMTel Supplementary Service Interaction and Configuration

2.4 Scenario 4 – Handovers

This scenario tests the different handover conditions both with registered terminals and with active sessions. There are three sub-test cases for this scenario, namely scenario 4a in which a Handover occurs between eNodeB's, scenario 4b in which a Handover occurs to/from LTE to 2G/3G access using an S4-SGSN, and scenario 4c in which a Handover occurs to/from LTE to 2G/3G access using a legacy version of the SGSN. The architectures for these scenarios are shown in the figures below.

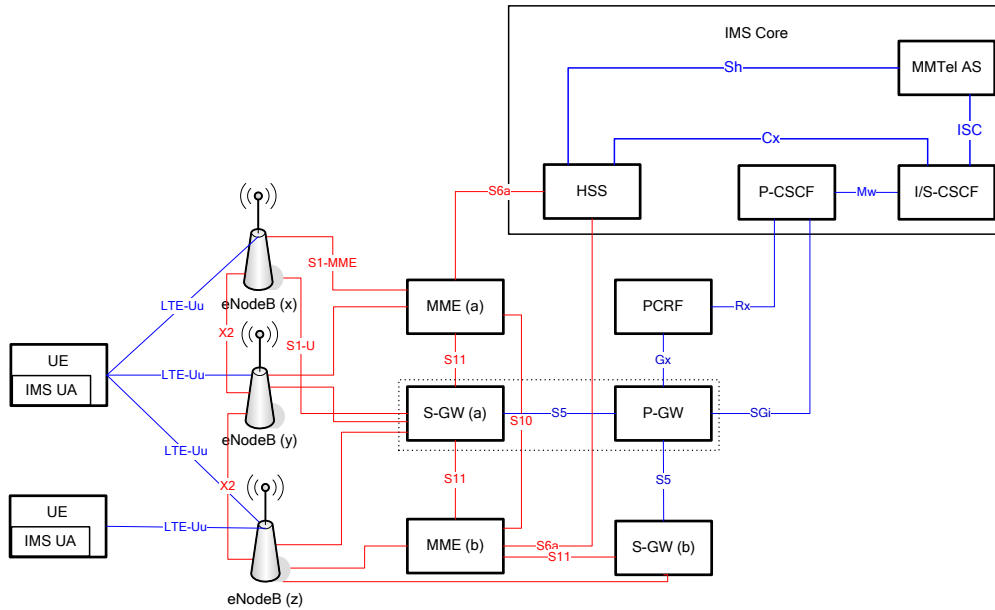

Figure 8 – Scenario 4a. Handovers between eNodeB's

NOTE: Diameter Routing Agent and Security Gateway are not displayed in the figure but are applied to the architecture.

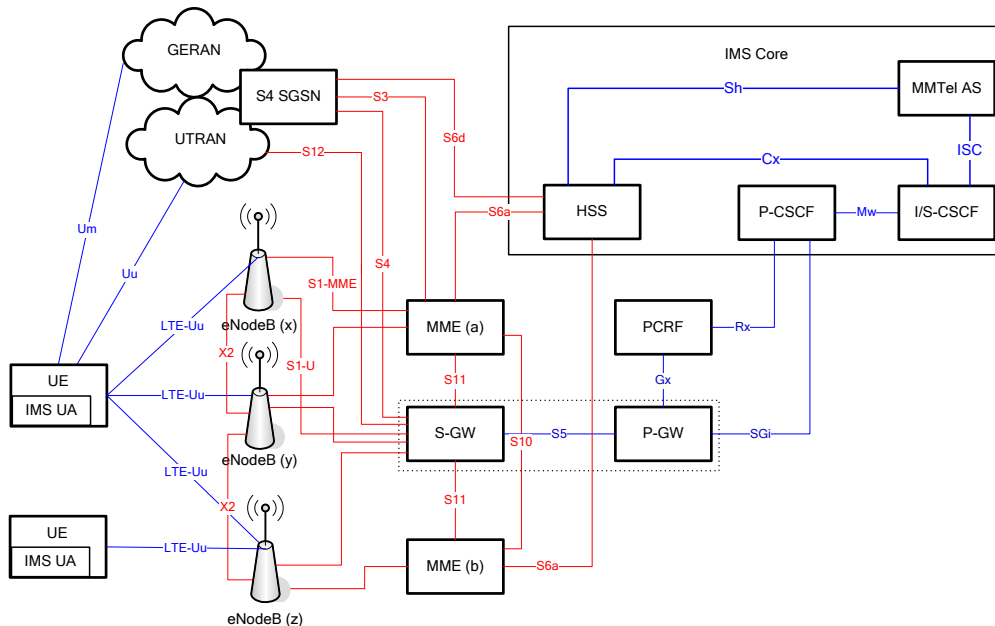

Figure 9 – Scenario 4b. Handovers to from LTE and 2G/3G with S4 SGSN

NOTE: Diameter Routing Agent and Security Gateway are not displayed in the figure but are applied to the architecture.

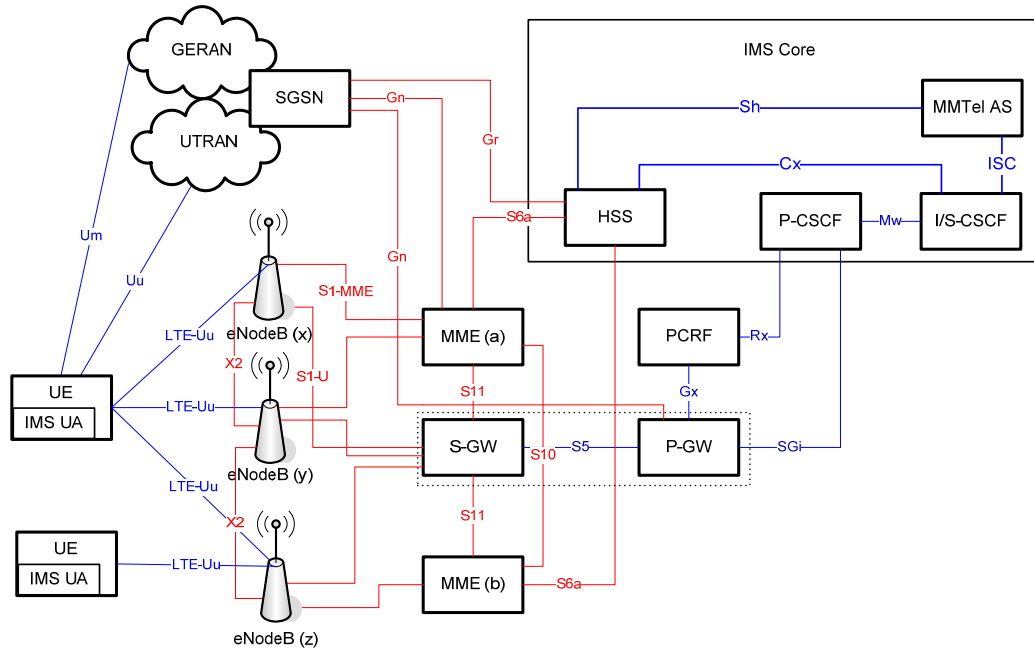

Figure 10 - Scenario 4c. Handovers to/from LTE and 2G/3G with legacy SGSN

NOTE: Diameter Routing Agent and Security Gateway are not displayed in the figure but are applied to the architecture.

2.4.1 Network Components

2.4.1.1 Scenario 4a

- Two LTE UE's with IMS User Agents
- Three eNodeB's
- Two MME
- One S-GW
- One P-GW
- One PCRF
- One HSS
- One P-CSCF
- One I/S-CSCF
- One MMTel Application Server
- One Sec-GW
- One DRA

2.4.1.2 Scenario 4b

- One Multi-mode (LTE – UTRAN/GERAN) UE
- One IMS UA on the Multi-mode UE
- One LTE UE
- One IMS UA on the LTE UE

- Three eNodeB's
- Two MME
- One S-GW
- One S4 SGSN
- GERAN/UTRAN access infrastructure.
- One P-GW
- One PCRF
- One HSS
- One P-CSCF
- One I/S-CSCF
- One MMTel Application Server
- One Sec-GW
- One DRA

2.4.1.3 Scenario 4c

- One Multi-mode (LTE – UTRAN/GERAN) UE
- One IMS UA on the Multi-mode UE
- One LTE UE
- One IMS UA on the LTE UE
- Three eNodeB's
- Two MME
- One S-GW
- One Legacy SGSN
- GERAN/UTRAN access infrastructure.
- One P-GW
- One PCRF
- One HSS
- One P-CSCF
- One I/S-CSCF
- One MMTel Application Server.
- One Sec-GW
- One DRA

2.4.2 Protocols and Reference Points

Interface	Protocol	Sub Scenarios
S1-MME	NAS	4a, 4b
S1-U	GTPv1-U	4a, 4b
X2	X2 AP (signalling) / GTPv1-U (user plane)	4a, 4b
S3	GTPv2-C	4a
S4	GTPv2-C (control plane) / GTPv1-U (user plane)	4a
S10	GTPv2-C	4a, 4b
S11	GTPv2-C	4a, 4b
S12	GTPv1-U	4a
S6a	Diameter	4a, 4b, 4c
S6d	Diameter	4b
Gn	GTPv1	4b, 4c
Gr	MAP	4b, 4c

2.4.3 Test Cases

The handover scenarios will be tested both for registered terminals and with established (IMS) sessions.

Basic Attachment.

-
- The Multimode UE attaches to eNB (y) and hands over to eNB(x), the Multimode UE remains attached.
 - The Multimode UE attaches to eNB(y) and hands over to eNB(z), moving from MME(a) to MME(b), the Multimode UE remains attached.
 - The Multimode UE attaches to eNB(y) and hands over to eNB(z), moving from S-GW(a) to S-GW(b), the Multimode UE remains attached.
 - The Multimode UE attaches to eNB (x) and hands over to UTRAN/GERAN, the Multimode UE remains attached.
 - The Multimode UE attaches to UTRAN/GERAN and hands over to eNB(x), the Multimode UE remains attached.

IMS Registration.

- The Multimode UE attached to eNodeB (y) and the UA registers with the IMS Core. The Multimode UE hands over to eNodeB(x), the UA remains registered with the IMS Core.
- The Multimode UE attaches to eNodeB(y) and the UA registers with the IMS Core. The Multimode UE hands over to eNodeB(z), moving from MME(a) to MME(b), the UA remains registered with the IMS Core.
- The Multimode UE attaches to eNodeB(y) and the UA registers with the IMS Core. The Multimode UE hands over to eNodeB(z), moving from S-GW(a) to S-GW(b), the UA remains registered with the IMS Core.
- The Multimode UE attaches to eNodeB (x) and the UA registers with the IMS Core. The Multimode UE hands over to UTRAN/GERAN, the UA remains registered with the IMS Core.
- The Multimode UE attaches to UTRAN/GERAN and the UA registers with the IMS Core. The Multimode UE hands over to eNodeB(x), the UA remains registered with the IMS Core.

IMS Session.

- The Multimode UE attaches to eNodeB (y) , the UA registers with the IMS Core and establishes an IMS voice session with the LTE UE that is also registered with the IMS. The Multimode UE hands over to eNodeB(x), the IMS voice session remains active.
- The Multimode UE attaches to eNodeB(y), the UA registers with the IMS Core and establishes an IMS voice session with the LTE UE that is also registered with the IMS. The Multimode UE hands over to eNodeB(z), moving from MME(a) to MME(b), the IMS voice session remains active.
- The Multimode UE attaches to eNodeB(y), the UA registers with the IMS Core and establishes an IMS voice session with the LTE UE that is also registered with the IMS. The Multimode UE hands over to eNodeB(z), moving from S-GW(a) to S-GW(b), the IMS session remains active.
- The Multimode UE attaches to eNodeB (x), the UA registers with the IMS Core and establishes an IMS voice session with the LTE UE that is also registered with the IMS. The Multimode UE hands over to UTRAN/GERAN, the IMS session remains active over the PS connection.
- The Multimode UE attaches to UTRAN/GERAN, the UA registers with the IMS Core and establishes an IMS voice session over the PS connection with the LTE UE that is also registered with the IMS. The Multimode UE hands over to eNodeB(x), the IMS session remains active.

2.5 Scenario 5 – Self-Organising Networks

In this scenario the focus on the S1 and X2 interface aspects of Self-Organising Networks are tested. This shall include aspects of Self Configuration (Dynamic configuration of the S1-MME interface, Dynamic Configuration of the X2 interface) and support of Automatic Neighbour Recognition within the UE and eNodeB.

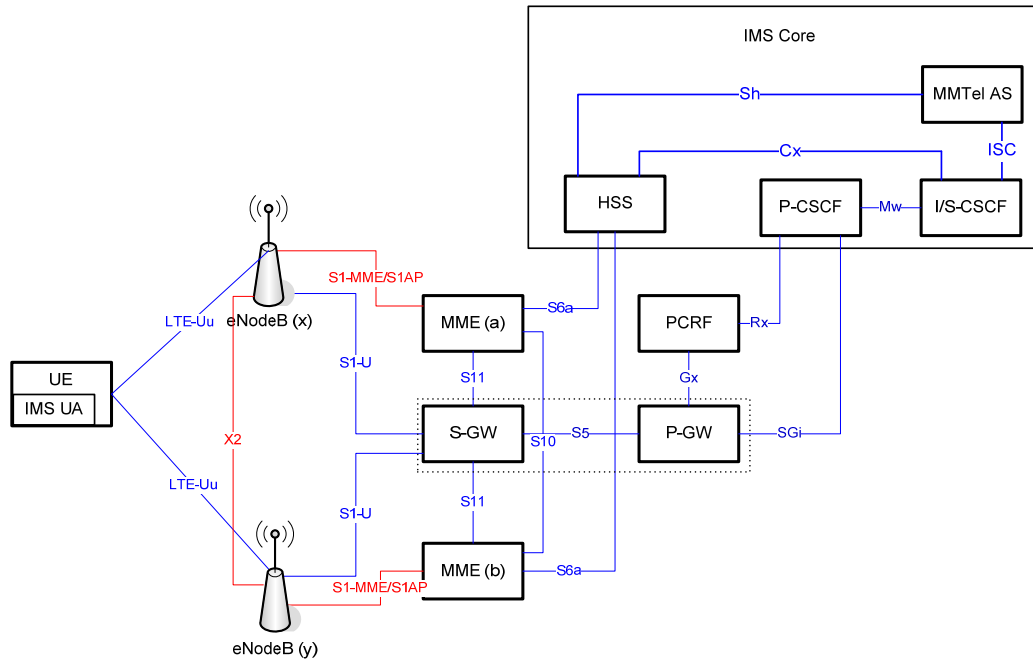

Figure 11 - Scenario 5a Physical Architecture – Basic Configuration

NOTE: Diameter Routing Agent and Security Gateway are not displayed in the figure but are applied to the architecture.

2.5.1 Network Components

2.5.1.1 Scenario 5a

- One LTE UE
- Two eNodeB's
- Two MME
- One S-GW
- One P-GW
- One PCRF
- One HSS
- One Sec-GW
- One DRA

2.5.2 Protocols and Reference Points

Interface	Protocol	Sub Scenarios
S1-MME	NAS	5a
S1-U	GTPv1-U	5a
S1AP	S1AP (S1 Application Protocol)	5a
X2	X2 AP (signalling) / GTPv1-U (user plane)	5a

2.5.3 Test Cases

- Dynamic allocation of Physical Cell Identifiers (PCI's) to eNodeB Cells
- Dynamic updating of Neighbour Relation Tables (NRT)
- Dynamic eNodeB to Core Network MME (S1-MME) Configuration
- Dynamic eNodeB to eNodeB (X2) Configuration

3 Interface Specifications

The following is a set of references for the interfaces tested in these scenarios.

- 3.1 LTE-Uu (UE – eNodeB)**
3GPP TS 36.300 (E-UTRAN protocol)
- 3.2 S1-MME (UE – MME)**
3GPP TS 24.301 (Non Access Stratum)
- 3.3 S1AP (eNodeB-MME)**
3GPP TS 36.413 (S1 Application Protocol)
- 3.4 S1-U (eNodeB - S-GW)**
3GPP TS 29.281 (GTPv1-U)
- 3.5 X2 (eNodeB – eNodeB)**
Signaling 3GPP TS 36.423 (X2 Application Protocol).
User Plane 3GPP TS 29.281 (GTPv1-U)
- 3.6 S3 (S4 SGSN – MME)**
3GPP TS 29.274 (GTPv2-C)
- 3.7 S4 (S4 SGSN – S-GW)**
Control Plane 3GPP TS 29.274 (GTPv2-C).
User Plane 3GPP TS 29.281 (GTPv1-U).
- 3.8 S5 (S-GW - P-GW)**
User Plane 3GPP TS 29.281 (GTPv1-U)
Control Plane 3GPP TS 29.274 (GTPv2-C)
- 3.9 S6a (HSS – MME)**
3GPP TS 29.272 (Diameter)
- 3.10 S6b (P-GW – 3GPP AAA)**
3GPP TS 29.273 (Diameter)
- 3.11 S6d (HSS – S4 SGSN)**
3GPP TS 29.272 (Diameter)
- 3.12 S8 (S-GW – P-GW)**
User Plane 3GPP TS 29.281 (GTPv1-U)
Control Plane 3GPP TS 29.274 (GTPv2-C)
- 3.13 S9 (PCRF – PCRF)**
3GPP TS 29.215 (Diameter).
- 3.14 S10 (MME – MME)**
3GPP TS 29.274 (GTPv2-C).
- 3.15 S11 (MME – S-GW)**
3GPP TS 29.274 (GTPv2-C)

- 3.16 S12 (UTRAN – S-GW)**
3GPP TS 29.281 (GTPv1-U, utilized for direct tunnel model).
- 3.17 Gx (PCRF – P-GW)**
3GPP TS 29.212 (Diameter).
- 3.18 Rx (PCRF - IP Application [P-CSCF for IMS])**
3GPP TS 29.214 (Diameter).
- 3.19 Gr (SGSN – HSS)**
3GPP TS 29.002 (MAP)
- 3.20 Gn (SGSN – MME / SGSN – P-GW)**
Control Plane 3GPP TS 29.060 (GTPv1-C)
User Plane 3GPP TS 29.281 (GTPv1-U)
- 3.21 Gm (UE – P-CSCF)**
3GPP TS 24.229 (IMS SIP)
- 3.22 Mw (x-CSCF – x-CSCF)**
3GPP TS 24.229 (IMS SIP)
- 3.23 ISC (S-CSCF – AS)**
3GPP TS 24.229 (IMS SIP)
- 3.24 Ut (UE – AS)**
3GPP TS 24.623 (XCAP)
- 3.25 SGi (EPC based PLMN and another packet data network)**
3GPP TS 29.061 (IP)

4 GSMA Permanent Reference Documents (PRDs)

The following is a set of GSMA PRDs to be tested in these scenarios.

- 4.1 IR.65: IMS Roaming & Interworking Guidelines**
- 4.2 IR.88: LTE Roaming Guidelines**
- 4.3 IR.92: IMS Profile for Voice and SMS**