



MSF Architecture for 3GPP Evolved Packet
System (EPS) Access Tile

MSFR5-ARCH-EPS-FINAL

MultiService Forum Architecture Agreement

Contribution Number: MSF2009.013.04
Document Filename: MSFR5-ARCH-EPS-FINAL
Working Group: Architecture
Title: **Architectural Framework for the
3GPP Evolved Packet System (EPS) Access Tile**

Editor: David Hutton
Contact Information: david.hutton@vodafone.com
+44 7920 271321

Working Group Chairperson: Stuart Walker

Abstract:

This document specifies the Architecture for the 3GPP Evolved Packet System (EPS) Access Tile for use with the MSF Architectural Framework.

DISCLAIMER

The information in this publication is believed to be accurate as of its publication date. Such information is subject to change without notice and the MultiService Forum is not responsible for any errors or omissions. The MultiService Forum does not assume any responsibility to update or correct any information in this publication. Notwithstanding anything to the contrary, neither the MultiService Forum nor the publisher make any representation or warranty, expressed or implied, concerning the completeness, accuracy, or applicability of any information contained in this publication. No liability of any kind whether based on theories of tort, contract, strict liability or otherwise, shall be assumed or incurred by the MultiService Forum, its member companies, or the publisher as a result of reliance or use by any party upon any information contained in this publication. All liability for any implied or express warranty of merchantability or fitness for a particular purpose is hereby disclaimed. The receipt or any use of this document or its contents does not in any way create by implication or otherwise: Any express or implied license or right to or under any MultiService Forum member company's patent, copyright, trademark or trade secret rights which are or may be associated with the ideas, techniques, concepts or expressions contained herein; nor Any warranty or representation that any MultiService Forum member companies will announce any product(s) and/or service(s) related thereto, or if such announcements are made, that such announced product(s) and/or service(s) embody any or all of the ideas, technologies, or concepts contained herein; nor Any commitment by a MultiService Forum company to purchase or otherwise procure any product(s) and/or service(s) that embody any or all of the ideas, technologies, or concepts contained herein; nor Any form of relationship between any MultiService Forum member companies and the recipient or user of this document.

Implementation or use of specific MultiService Forum Implementation Agreements, Architectural Frameworks or recommendations and MultiService Forum specifications will be voluntary, and no company shall agree or be obliged to implement them by virtue of participation in the MultiService Forum.

For addition information contact:

MultiService Forum
48377 Fremont Blvd, Suite 117, Fremont, CA 94538
Phone: (510) 492-4050 Fax: (510) 492-4001
info@msforum.org WWW.MSFORUM.ORG
© MultiService Forum 2008

I. The MultiService Forum

The MultiService Forum (MSF) is a global association of service providers, system suppliers and other organizations committed to developing and promoting open-architecture, multiservice communication systems. Founded in 1998, the MSF is an open-membership organization comprised of the world's leading telecommunications companies.

The MSF's activities include developing implementation agreements, promoting worldwide compatibility and interoperability, and encouraging input to appropriate national and international standards bodies.

As part of MSF's effort to drive and promote interoperability, the MSF has created a number of programs geared toward accelerating real world network deployments:

1. Global MSF Interoperability (GMI) events. GMI events provide a real-world setting for vendors to test their solutions and provide evidence that vendor products meet the interoperability standards set forth by MSF Implementation Agreements. Each MSF GMI event is built around a set of capabilities defined for a given release of the MSF Architecture.
2. Next Generation Network (NGN) Test Bed. The NGN test bed provides a facility to enable carriers and vendors to perform in-depth testing of a specific interface as defined in a given release of the MSF architecture.
3. Certification Programs. For more mature technologies the MSF can provide Certification of compliance to a given Implementation Agreement where MSF members believe that it is of value to the industry to do so.

II. An introduction to MSF R5 documentation

This document is part of the MSF Release 5 set of architectural, protocol and test documentation.

The MSF Release 5 Architecture is a physical implementation of the functional architectures that have been proposed by the key Standards Development Organizations. As such the MSF Release 5 Architecture represents the current state of the industry and it identifies current open interfaces between physically separate network elements.

MSF Implementation Agreements define the protocols to be used over specific open interfaces. Where possible MSF Implementation Agreements are based on industry standard protocols augmented with additional information so as to ensure interoperability between communicating network elements. This level of interoperability is achieved by closing any gaps and tightening any optional capabilities in those industry standards to remove the danger of mutually incompatible selections by vendors. An MSF Implementation Agreement is targeted at a given release of the MSF architecture but can be used in any circumstance where an operator wishes to deploy the open interface and its functionality within their own network.

The MSF Release 5 architecture and its associated implementation agreements are used as the basis for MSF Interoperability Events in the 2009-10 timeframe.

Detailed test scenarios will be developed and a number of test plans defined for any given MSF Interoperability Event. Test plans contain the set of test cases required to demonstrate a given MSF Release 5 capability and serve to exercise and validate the set of Implementation Agreements required to realize the capability.

Following the completion of a MSF Interoperability Event, the MSF Release 5 architecture and individual implementation agreements will be updated if the testing identifies any deficiencies in the documents.

For more information about the scope of MSF Interoperability Events, please go to <http://www.msforum.org>

III. Impact on previously published MSF documents

- This is a new specification for MSF Release 5.

Table of Contents

MultiService Forum	2
Architecture Agreement	2
1. Introduction	6
1.1. Scope	6
1.2. Tile Prefix	6
1.3. References	6
1.4. Definitions and Abbreviations	8
1.4.1. Definitions	8
1.4.2. Abbreviations	10
2. Purpose	10
3. Overview of Relationship with the MSF Architectural Framework	10
4. 3GPP Evolved Packet System (EPS) Access Tile Generic Architecture Overview	13
5. Trust Boundaries	14
6. Element Definitions	14
6.1. eNode B	15
6.2. S4-SGSN	15
6.3. MME	15
6.4. SGW	16
6.5. PGW	16
6.6. HSS	17
6.7. UE	17
7. Principles of operation	17
7.1. 3GPP EPS IP-CAN E-UTRAN Attach	17
7.2. GERAN/UTRAN Attach	17
7.3. Mobility Management and Handover	17
7.4. Location Based Services	18
8. External Reference points	18
9. Internal Reference points	19

Table of Figures

Figure 1: Generic Relationship of the Access Domain within MSF Architectural Framework	12
Figure 2: 3GPP Evolved Packet System Access Tile Architecture (S4-SGSN)	13

1. Introduction

1.1. Scope

This document defines the access tile architecture for the 3GPP Evolved Packet System (EPS) service. It includes the network attachment procedure for various access network configurations and the derivation of location information. It also includes bandwidth / QoS management of the media path.

1.2. Tile Prefix

The Tile Prefix for the 3GPP Evolved Packet System access tile SHALL be “EPS”

1.3. References

- [1] MSFR4-ARCH-OVERVIEW-FINAL, MSF Release 4 Architecture Overview
- [2] MSFR5-ARCH-CORE-FINAL, MSF Release 5 Core Architecture
- [3] MSFR5-ARCH-ACCESS-FINAL, MSF Release 5 Access Architectural Framework
- [4] 3GPP TS 23.002: "Network Architecture (Release 8)"
- [5] 3GPP TS 23.203: "Policy Control and Charging Architecture (Release 8)"
- [6] 3GPP TS 25.430: "UTRAN Iub Interface: general aspects and principles (Release 8)"
- [7] 3GPP TS 35.431: "UTRAN Iub interface Layer 1 (Release 8)"
- [8] 3GPP TS 25.432: "UTRAN Iub interface: signalling transport (Release 8)"
- [9] 3GPP TS 25.433: "UTRAN Iub interface Node B Application Part (NBAP) signaling (Release 8)"
- [10] 3GPP TS 25.434: "UTRAN Iub interface data transport and transport signalling for Common Transport Channel data streams (Release 8)"
- [11] 3GPP TS 25.435: "UTRAN Iub interface user plane protocols for Common Transport Channel data streams (Release 8)"
- [12] 3GPP TS 25.410: "UTRAN Iu interface: General aspects and principles (Release 8)"
- [13] 3GPP TS 25.411: "UTRAN Iu interface layer 1 (Release 8)"

- [14] 3GPP TS 25.412: "UTRAN Iu interface signalling transport (Release 8)"
- [15] 3GPP TS 25.413: "UTRAN Iu interface Radio Access Network Application Part (RANAP) signaling (Release 8)"
- [16] 3GPP TS 25.414: "UTRAN Iu interface data transport and transport signaling (Release 8)"
- [17] 3GPP TS 25.415: "UTRAN Iu interface user plane protocols (Release 8)"
- [18] 3GPP TS 25.420: "UTRAN Iur interface general aspects and principles (Release 8)"
- [19] 3GPP TS 25.421: "UTRAN Iur interface layer 1 (Release 8)"
- [20] 3GPP TS 25.422: "UTRAN Iur interface signalling transport (Release 8)"
- [21] 3GPP TS 25.423: "UTRAN Iur interface Radio Network Subsystem Application Part (RNSAP) signaling (Release 8)"
- [22] 3GPP TS 25.424: "UTRAN Iur interface data transport & transport signalling for Common Transport Channel data streams (Release 8)"
- [23] 3GPP TS 25.425: "UTRAN Iur interface user plane protocols for Common Transport Channel data streams (Release 8)"
- [24] 3GPP TS 25.426: "UTRAN Iur and Iub interface data transport & transport signalling for DCH data streams (Release 8)"
- [25] 3GPP TS 25.427: "UTRAN Iur/Iub interface user plane protocol for DCH data streams (Release 8)"
- [26] 3GPP TS 29.060: "General Packet Radio Service (GPRS); GPRS Tunnelling Protocol (GTP) across the Gn and Gp interface (Release 8)"
- [27] 3GPP TS 29.002: "Mobile Application Part (MAP) specification (Release 8)"
- [28] 3GPP TS 23.401: "General Packet Radio Service (GPRS) enhancements for Evolved Universal Terrestrial Radio Access Network (E-UTRAN) access (Release 8)"
- [29] void
- [30] msf.2008.160: "Architectural Framework for the 3GPP Packet-Switched Access Tile"
- [31] 3GPP TS 36.420: "Evolved Universal Terrestrial Radio Access Network (E-UTRAN); X2 general aspects and principles (Release 8)"

- [32] 3GPP TS 36.421: "Evolved Universal Terrestrial Radio Access Network (E-UTRAN); X2 layer 1 (Release 8)"
- [33] 3GPP TS 36.422: "Evolved Universal Terrestrial Radio Access Network (E-UTRAN); X2 signalling transport (Release 8)"
- [34] 3GPP TS 36.423: "Evolved Universal Terrestrial Radio Access Network (E-UTRAN); X2 Application Protocol (X2AP) (Release 8)"
- [35] 3GPP TS 36.424: "Evolved Universal Terrestrial Radio Access Network (E-UTRAN); X2 data transport (Release 8)"
- [36] 3GPP TS 24.301: "Non-Access-Stratum (NAS) protocol for Evolved Packet System (EPS); Stage 3 (Release 8)"
- [37] 3GPP TS 29.274: "3GPP Evolved Packet System (EPS); Evolved General Packet Radio Service (GPRS) Tunnelling Protocol for Control plane (GTPv2-C); Stage 3 (Release 8)"
- [38] 3GPP TS 29.281: "General Packet Radio System (GPRS) Tunnelling Protocol User Plane (GTPv1-U) (Release 8)"
- [39] 3GPP TS 29.272: "Evolved Packet System (EPS); Mobility Management Entity (MME) and Serving GPRS Support Node (SGSN) related interfaces based on Diameter protocol (Release 8)"
- [40] 3GPP TS 29.212: "Policy and charging control over Gx reference point (Release 8)"

1.4. Definitions and Abbreviations

1.4.1. Definitions

The key words "MUST", "MUST NOT", "REQUIRED", "SHALL", "SHALL NOT", "SHOULD", "SHOULD NOT", "RECOMMENDED", "NOT RECOMMENDED", "MAY", "OPTIONAL", "CONDITIONAL" and "IF" in this document are to be interpreted as described in the MSF Technical Committee Operating Procedures.

Access Network Domain	The part of the overall MSF architecture framework that generically represents an access network, independent of its technology
Access Network Tile	A specification of the architecture for a specific access network technology or a grouping of similar access technologies.

MSF Core Architecture Domain	The functionality contained in the Transport, Session and Common Blocks defined in the MSF Architecture [2]
Customer Domain	The part of the overall MSF architecture framework that represents equipment residing with the customer or end user.

1.4.2. Abbreviations

3GPP	Third Generation Partnership Project
AF	Application Function
BSC	Base Station Controller
BSS	Base Station Subsystem
BTS	Base Transceiver System
GGSN	Gateway GPRS Support Node
GPRS	General Packet Radio Service
GTP	GPRS Tunnelling Protocol
GTP-C	GTP Control
GTP-U	GTP User
HSS	Home Subscriber Server
IMS	IP Multimedia System
MAP	Mobile Application Part
NGN	Next Generation Networks
OFCS	Offline Charging System
PCC	Policy and Charging Control
PCEF	Policy and Charging Enforcement Function
PCRF	Policy and Charging Rule Function
PDSN	Packet Data Serving Node
PLMN	Public Land Mobile Network
PS	Packet Switched
RANAP	Radio Access Network Application Part
RNC	Radio Network Controller
P-CSC	Proxy-Call Session Control
PCRS	Policy Charging Rules Server
RAN	Radio Access Network
SGSN	Serving GPRS Support Node
S-CSC	Serving-Call Session Control
SBBC	Session Based Bearer Control
UE or MS	User Equipment or Mobile Subscriber
UMTS	Universal Mobile Telecommunications System

2. Purpose

This Access Network Tile is used to service a device that is IMS aware and attaches to an Evolved Packet System enabled network to offer traditional telephony / multimedia services within a converged NGN network. Note that the EPS access tile provides access for terminals connecting via the LTE radio access, GERAN radio access, and UTRAN radio access. Access for non-3GPP defined trusted/untrusted access technology (e.g. xDSL, WiFi access point, etc.) is FFS.

3. Overview of Relationship with the MSF Architectural Framework

The MSF Release 4 architecture [1] introduced an Access Network Domain into its architectural framework (see Figure 1). The Access Network Domain has a number of

standard interfaces defined that are independent of the network access technology. This allows the architectural framework to define the interaction between the MSF core architecture domain and access network entities in order to support common capabilities such as extracting location information associated with access network attachment and managing access bandwidth allocation. As access technologies differ from one another, so do the mechanisms internal to that access network domain that support these interfaces. To accommodate this, a generic access domain is defined with the MSF architectural framework with common interfaces [3]. To facilitate adding different and multiple access networks to the overall architecture, each access network technology or group of similar technologies is defined in its own 'Access Network Tile' architecture that can be substituted for the generic access domain. Each Access Network Tile specifies how it operates internally and supports a sub-set of the common interfaces with the MSF Core Architecture Domain [2].

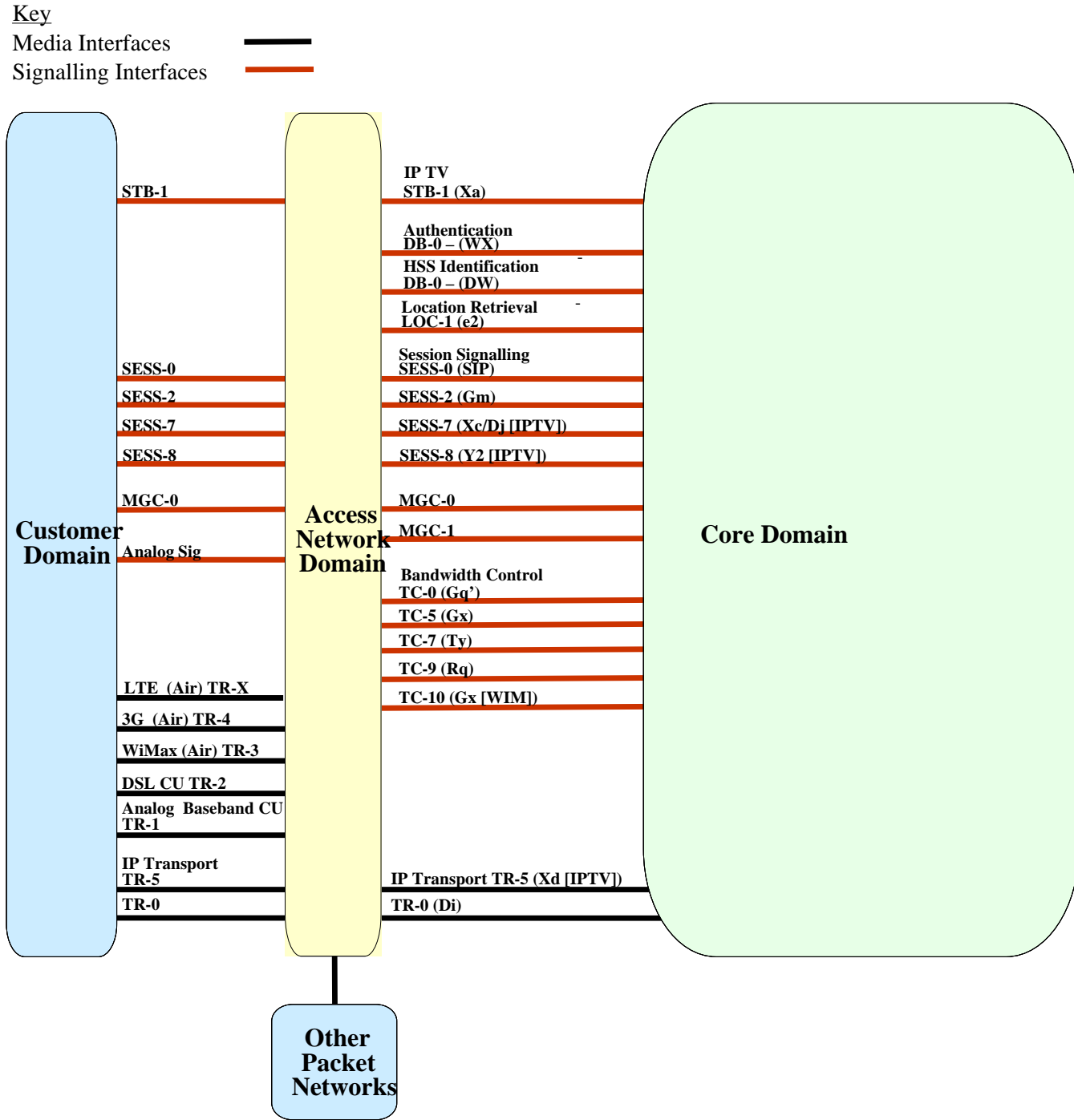

Figure 1: Generic Relationship of the Access Domain within MSF Architectural Framework

The common interfaces between the MSF Core Architecture Domain and the Access Block are for Bandwidth Control (TC-5) and IP transport (TR-0).

4. 3GPP Evolved Packet System (EPS) Access Tile Generic Architecture Overview

The figure below is a representation of the network elements that help form the basis of a 3GPP defined Evolved Packet System network that is capable of interworking with an IMS network and deliver IMS services to the end user. The architecture is based on the principles defined in 3GPP TS 23.002 [4] and 3GPP TS 23.401 [28].

NOTE: In Figure 2 and Figure 3, certain nodes may be physically collocated with each other. E.g. SGW collocated with PGW (in non-roaming scenarios), P-CSC in the access network collocated with S-SBG-NE in the MSF IMS Core Network. The HSS is collocated with HSS in MSF IMS Core Network.

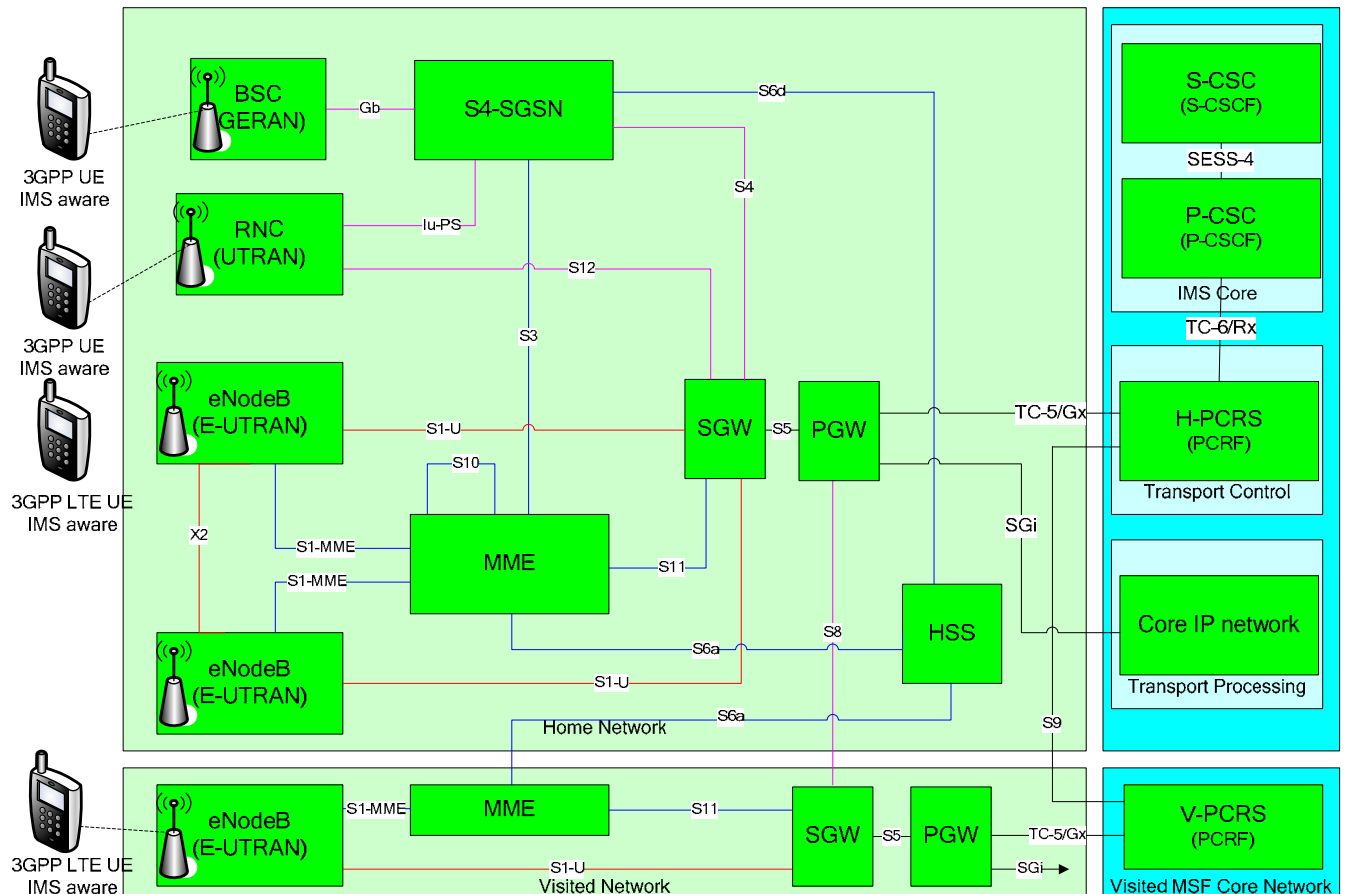

Figure 2: 3GPP Evolved Packet System Access Tile Architecture (S4-SGSN)

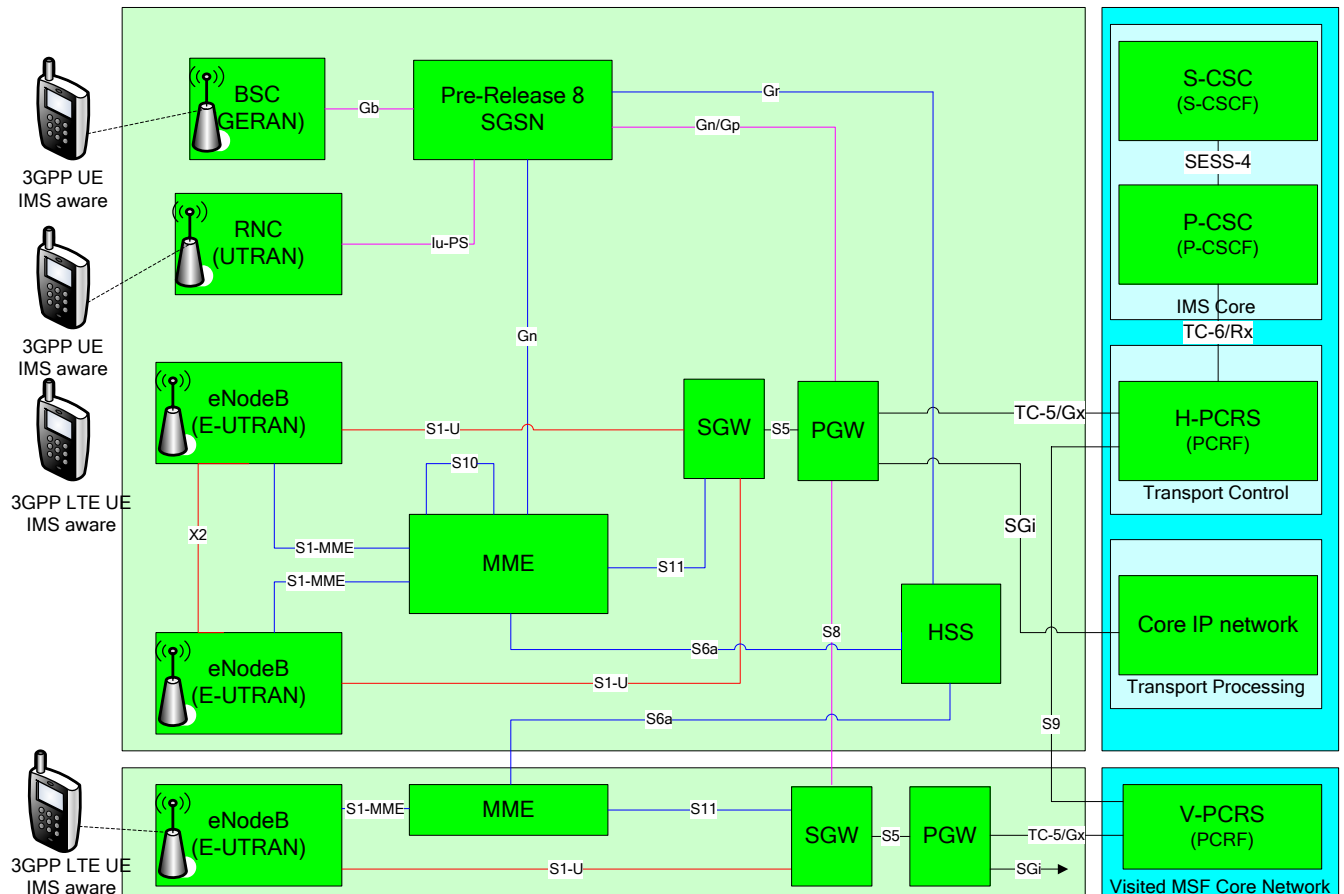

Figure 3: 3GPP Evolved Packet System Access Tile Architecture (Pre-Release 8 SGSN)

5. Trust Boundaries

The 3GPP defined EPS Access Network tile SHALL be in the same trust domain as the MSF core network to which it is connected. The signalling capability from the customer equipment is very limited thus restricting the ability of a user to adversely interact with the network. Within these constraints the customer equipment may also be regarded as part of the same trust domain. The IP connectivity within the 3GPP EPS Access Tile COULD use the same address space as the core domain.

6. Element Definitions

Definition of UTRAN components (Node B, RNC, and pre-Release 8 SGSN) are defined within the 3GPP PS Access Tile, see msf.2008.160 [30].

6.1. eNode B

The eNode B is responsible for providing the air interface channels for the mobile handset to listen and attach. It enables delivery of mobile broadband data services and is connected to other eNode B's via the X2 interface in order to provide handover functionality. X2 interface is defined within 3GPP TS 36.42x series [31] to [35].

The eNodeB provides the capability to backhaul both control plane (S1-MME) and user plane (S1-U) to the Evolved Packet Core. S1 interface is defined within 3GPP TS 24.301 [36].

6.2. S4-SGSN

The S4-SGSN (Serving GPRS Support Node) supports the legacy access type for UTRAN and GERAN.

As with the pre-Release 8 SGSN, the S4-SGSN delivers data packets to/from the UE within its geographical service area. It is responsible for packet routing, mobility management, subscriber authentication, charging functions, and storage of subscription information and location information.

The S4-SGSN communicates with the RNC (UTRAN) via the Iu-PS Interface as defined in section 3GPP TS 25.41x series [12] to [17]. Bearers are established for both the control plane (RANAP) and user plane (GTPv1-U).

The S4-SGSN communicates with the HSS via the S6d interface as defined within 3GPP TS 29.272 [39]. This is utilized for retrieving authentication information, storage of subscription information and location information

The S4-SGSN is enhanced to support the S4 Interface which provides related control and mobility support between GPRS Core and the 3GPP Anchor function of SGW. The control plane specifies a tunnel control and management protocol (GTPv2-C), allowing access to a packet data network for the UE. GTPv2-C is defined in 3GPP TS 29.274 [37]. The user plane uses a tunneling mechanism (GTPv1-U) to deliver user data packets. The tunneling mechanism is achieved by creation of a Packet Data Protocol (PDP) Context in the SGSN and the GGSN. The PDP Context binds together both control and user plane and is utilized to transfer authentication procedures, allocation of an IP Address to the UE, download of Access Point Name, etc. The user plane is defined in 3GPP TS 29.281 [38].

The S4-SGSN is also enhanced to support S3 Interface which enables user and bearer information exchange for inter 3GPP access network mobility. The S3 interface also utilizes GTPv2-C.

6.3. MME

The Mobility Management Entity (MME) supports the control plane signaling from the E-UTRAN and also performs security and authentication mechanisms for the subscriber.

Communication with the eNodeB for the control plane is achieved with the S1-MME interfaces as defined within 3GPP TS 24.301 [36].

The MME communicates with the HSS via the S6a interface as defined within 3GPP TS 29.272 [39]. This is utilized for retrieving authentication information, storage of subscription information and location information

The MME also supports the S3 and S10 Interfaces which enables user and bearer information exchange for inter 3GPP access network mobility. The S3 and S10 interfaces utilize GTPv2-C as defined in 3GPP TS 29.274 [37].

The MME supports the S11 Interface which provides related control and mobility support between the E-UTRAN and the 3GPP Anchor function of SGW. SGW and PGW selection occurs within the MME, to be used for the control plane to specify a session and bearer management (GTPv2-C), allowing access to a packet data network for the UE. GTPv2-C is defined in 3GPP TS 29.274 [37].

6.4. SGW

The Serving Gateway (SGW) is a combined physical node with two logical parts, the Serving Gateway and the Packet Data Network Gateway.

The Serving Gateway terminates the user-plane of the E-UTRAN access (S1-U) and provides the local mobility anchor point for inter-eNodeB handover. The S1-U interface is defined within 3GPP TS 24.301 [36].

The Serving Gateway provides mobility anchoring for inter-3GPP mobility, terminating the S4 interface and relaying the traffic between 2G/3G system and the Packet Data Network Gateway.

The Serving Gateway also provides packet routing and forwarding between the PDN Gateway and 3GPP access network and transport level packet marking (e.g. DSCP) in the uplink and the downlink direction.

6.5. PGW

The Packet Data Network Gateway (PGW) provides interworking with packet data networks via the SGi interface, and contains routing information for attached users to route packets to/from the current SGW serving the UE for E-UTRAN access, UTRAN access, GERAN access, and roaming scenarios. Functionality for roaming scenarios is provided using the S8 interface for both control and user plane. Control plane is provided by utilising GTPv2-C as defined in 3GPP TS 29.274 [37], whilst user plane is provided by utilising GTPv1-U as defined in 3GPP TS 29.281 [38].

When acting as a PCEF the PGW also performs UL and downlink service level charging, UL and DL service level gating control and service level rate enforcement, UL and DL bearer binding and UL bearer binding verification. This functionality is achieved by utilising the Gx interface to communicate with the PCRS as defined in 3GPP TS 29.212 [40].

6.6. HSS

The Home Subscriber Server is a central database that contains details of each subscriber that is authorized to use the 3GPP defined access networks.

The HSS contains subscription data for GPRS subscribers, subscription data for EPS subscribers and routing information. The HSS is accessible from the S4-SGSN via the S6d interface and from the MME via the S6a interface, both interfaces specified in 3GPP TS 29.272 [39]. For roaming scenarios, the HSS may be in a different PLMN than the current S4-SGSN/MME.

The HSS also contains the authentication vectors for the S4-SGSN/MME to utilize during authentication procedures. Authentication of the UE occurs within the S4-SGSN/MME for 3GPP access networks.

6.7. UE

The User Equipment (UE) is the subscriber device supported by the 3GPP access network and is loaded with an IMS aware client. This device may support GERAN access, UTRAN access, or E-UTRAN access to EPS.

7. Principles of operation

7.1. 3GPP EPS IP-CAN E-UTRAN Attach

A UE/user needs to register with the network to receive services that require registration. This registration is described as Network Attachment. The always-on IP connectivity for UE/users of the EPS is enabled by establishing a default EPS bearer during Network Attachment. The PCC rules applied to the default EPS bearer may be predefined in the PDN GW and activated in the attachment by the PDN GW itself. The Attach procedure may trigger one or multiple Dedicated Bearer Establishment procedures to establish dedicated EPS bearer(s) for that UE. PCC rules may also be applied to dedicated bearers or may be predefined in the PDN GW upon activation.

E-UTRAN Attach procedures are defined within 3GPP TS 23.401 [28].

7.2. GERAN/UTRAN Attach

GERAN/UTRAN Attach procedures are as defined within msf2008.160 [30].

7.3. Mobility Management and Handover

The location of a UE in idle state is known by the network on a Tracking Area List granularity. A UE in idle state is paged in all cells of the Tracking Areas in which it is currently registered. The UE may be registered in multiple Tracking Areas. All the tracking areas in a Tracking Area List to which a UE is registered are served by the same serving MME. An UE in registered state performs periodic Tracking Area Updates with the network after the expiry of the periodic TAU timer.

Tracking Area Update procedures are defined within 3GPP TS 23.401 [28].

The location of a UE in the connected state is known by the MME with an accuracy of a serving eNodeB ID. Mobility of the UE in this state is handled by Handover procedures. Intra E-UTRAN Handover, X2-based (eNodeB to eNodeB with potential SGW relocation) and S1-based (relocation between MME's with potential SGW relocation) are defined within 3GPP TS 23.401 [28]. Inter-RAT Handover between E-UTRAN and UTRAN/GERAN are defined within 3GPP TS 23.401 [28].

7.4. Location Based Services

Location Based services for EPS are currently not defined within 3GPP Release 8, and are therefore FFS.

8. External Reference points

The User Equipment is connected over the air interface to the RAN and PS Access Network that is capable of connecting to an IMS enabled network. To access the IMS network the customer equipment needs to be provisioned with an IMS aware client / configuration.

When the user attaches to the network it is authenticated by the HSS by using the S6a/S6d interface. The user is also authenticated by the HSS located in the IMS network over the SESS-2, SESS-4, Cx interfaces

Application level session information is downloaded by the P-CSCF to the PCRF via the Rx Interface. This information is utilized by the PCRF in order to exchange PCC rules with the PGW, over the Gx interface, in order to enforce the policy.

Since this access tile supports IP connectivity to the customer it can support IP enabled services like Presence, IPTV, Instant Messaging, VoIP etc...

The 3GPP EPS Access tile supports IP transport (TR-0) towards the Core

Interface Designation	3GPP Equivalent	Description	Protocol	MSF IA
Transport Interfaces				
TR-0	SGi	IP Interconnect to/from the core	N/A	N/A
Session Signalling				
SESS-2	Gm	SIP Protocol for session initiation	SIP	MSF-IA-SIP.016-FINAL
Bandwidth management				
TC-5	Gx	Between PGW and PCRS for Policy rules enforcement in 3GPP EPS networks	Diameter	N/A

9. Internal Reference points

Interface Designation	3GPP Equivalent	Description	Protocol	MSF IA
3GPP EPS Network				
	E-UTRAN Uu	3GPP defined Air Interface between UE and 3GPP RAN		Currently not specified
	X2	Between two eNodeB's to address mobility handoffs		Currently not specified
	S1-MME	Between eNodeB and MME for transfer of control plane information	GTPv1-C	Currently not specified
	S1-U	Between eNodeB and SGW for transfer of user plane	GTPv2-U	Currently not specified
	S3	Between S4-SGSN and MME for inter-3GPP access mobility	GTPv2-C	Currently not specified
	S4	Between S4-SGSN and SGW for control plane and user plane connectivity of legacy access to EPS	GTPv2-C GTPv1-U	Currently not specified
	S6a	Between the MME and HSS for user authentication, access to user subscription data, and location update.	Diameter	Currently not specified
	S6d	Between the S4-SGSN and HSS for user authentication, access to user subscription data, and location update.	Diameter	Currently not specified
	S8	Between SGW in V-PLMN and the PGW in the H-PLMN for control plane and user plane connectivity	GTPv2-C GTPv1-U	Currently not specified
	S9	Between PCRS in V-PLMN and H-PLMN	Diameter	Currently not specified
	S10	Between MME's for mobility handoff's	GTPv2-C	Currently not specified
	S11	Between MME and SGW for control plane connectivity	GTPv2-C	Currently not specified
	S12	Between RNC and SGW for Direct Tunnel	GTPv1-U	Currently not specified
	Gn/Gp	Between pre Rel-8 SGSN's for both control plane and user plane to create a tunneling mechanism to allow transport of multi-protocol packets.	GTPv1-C GTPv1-U	Currently not specified
	Gr	Between pre Rel-8 SGSN and HSS for user	MAP	Currently not specified

		authentication and transfer of billing data		
--	--	--	--	--

--- End of Document ---